

Quad sampler, type 6900-10

Online sampling during milk collection

- Four samples simultaneously
- Continuous sampling
- Load sample
- Quality sample
- Component sample
- Grab Sample
- Quadruple RFID Reader
- Peristaltic principle
- Minimum carry over
- High representativity
- Secure sample identification
- Tamper-proof sample locking
- Inline sampling
- Easy cleaning
- Clear design
- Compact unit
- Easily exchangeable
- Large dynamic range
- Complies with DIN 11868-1



Description/function

The Quad Sampler, type 6900-10, can carry out online sampling by drawing up to four samples simultaneously from the collection pipe. It is equipped with four step motors; each one drives a peristaltic pump. The speed of the pump is calculated from the sample volume, the collection volume and the relevant volume flow. From the three factors the control electronics, type 6930-10, generates a variable pump speed, which is proportional to the volume flow and so fills a highly representative sample into the sample vial.

Feed and withdrawal of the sample vial are semi-automatic.

In the bottom area of the sampling device there are four RFID-Reader/Writers, which continuously read out and write on the TAG in the bottom area of the sample vial. This guarantees a unique assignment of the sample vial, which is recorded by the evaluation electronics. The central computer administers the complete sampling sequence, by writing default data into the sample control, type 6930-108 and 6930-109, and retrieving status data. Due to the structural design and a patented rinsing method, there is only a minimal carry over.

Application

The sampling system is suitable for online sampling during milk collection, and during milk delivery where required. In connection with a flowmeter and a filling level sensor, where applicable, it is able to generate a representative sample for different collection quantities and different collection modalities.

The intake quantity, out of which an invariable sample quantity of approx. 40 ml is drawn, can be in the range from 30 l to 30,000 l. The system also makes possible to generate a representative load sample as well as a spot check.

The four samplers work simultaneously.

Technical data

Device-specific data

Nominal conditions	23 ± 2 °C
--------------------	-----------

Electrical data

Auxiliary energy	DC 24 V	Supply from Sampler Controller, type 6930-102
Power consumption	2x130 mA	
Interface	RS 232, 4 x Rx/D, Tx/D; DC 24 V	
Baudrate	Max. 38.400 b/s	
Galvanic separation	None	
Cable length	Max. 5 m	
Connection	2 Cable, 7 x 0,25 - wire, shielded	
Protocol	ISO 15693	
Number of Reader/Writers	4	
Read/write distance	Max. 30 mm	

Electrical data - Sampler control

Auxiliary energy	24 ... 36 V
Power consumption	Max. 4 A
Step frequency	Max. 10 kHz (corresponds to 25 rev/sec for 400 steps)
Number of samplers	4
Connection	2 cables, 10 x 0,5-wire, shielded

Ambient conditions

Operating temperature	- 10 ... + 50 °C
Storage temperature	- 20 ... + 70 °C
Protective type	IP 66
Climatic classification	IWFn in accordance with DIN 40040

Mechanical data

Dimensions	See drawing
Materials that have contact to milk	POM, 1.4301
Weight	Approx. 10 kg

Dimensions

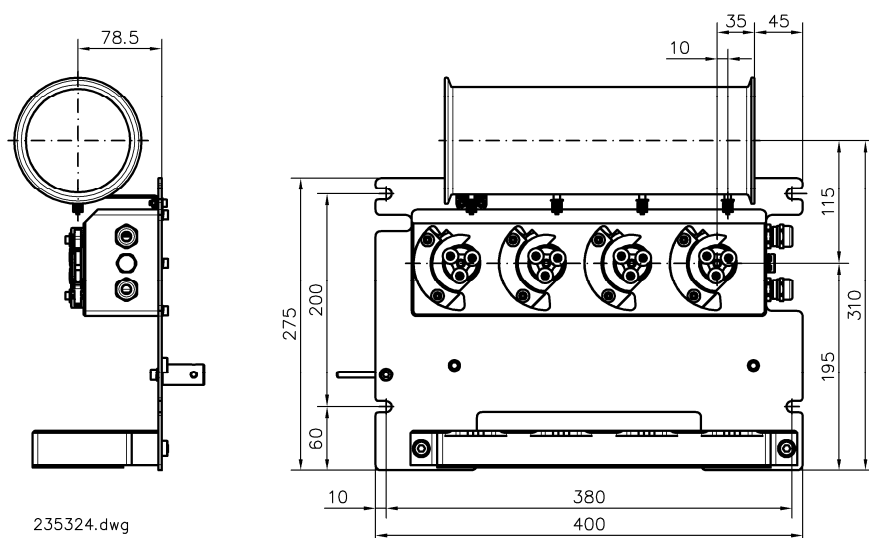

Ordering details

Designation	Order no.
Quad sampler, type 6900-10	235 324
Accessory	
Attachment for bottles type 6900-304	246 064