



The RDA01 evaluation unit is a component of the BARTEC water detection system. It operates in conjunction with the SCR sensor cable and/or the PS point sensor. Other components of the BARTEC water detection system are the RLW and RDW03 evaluation units, as well as accessories (see catalogue).

**Description**

The system quickly and reliably detects small leakages of liquid, producing a visual and acoustic alarm signal. At the same time, floating contacts are set for messages to the building management system (BMS) and for control tasks.

**Safety instructions**

The device may only be used within the specified ambient and operating temperature range. Use in areas other than those specified or the alteration of the product by somebody other than the manufacturer is not permitted and releases BARTEC from liability for defects and other liability. Malfunctions may result from incorrect installation. The generally applicable statutory regulations and other binding guidelines relating to occupational health and safety, accident prevention and environmental protection must be complied with. Applicable laws and guidelines must be complied with before commissioning or putting back into operation. The equipment may only be used in a clean, undamaged state. Modifications and changes are not permitted.

**Marking**

Particularly important points in these instructions are marked with a symbol:

**DANGER**

DANGER indicates a hazardous situation which, if not avoided, will result in death or serious injury.

**WARNING**

WARNING indicates a hazardous situation which, if not avoided, could result in death or serious injury.

**CAUTION**

CAUTION indicates a hazardous situation which, if not avoided, could result in minor or moderate injury.

**NOTICE**

NOTICE is used to address practices not related to personal injury.

**NOTE**

Important instructions and information on effective, economical and environmentally compatible handling.

**Compliance with standards**

EN 61010-1, EN 60335-1, EN 61000-6-2, EN 61000-3-2, EN 61000-3-3, EN 61000-6-3, EN 60529

**Mounting, installation and commissioning**

**WARNING**

Risk of injury due to incorrect procedure.

- All work concerning mounting, dismantling, installation and commissioning may only be conducted by authorised qualified personnel.
- Pay attention to the type of installation (for installation /with connection enclosure).
- Use suitable tools.

**Mounting/dismantling**

The monitoring electronics are snapped onto a TS 35 top-hat rail inside the control cabinet.

**Installation**

Take the following into consideration when connecting conductors:

- Remove approx. 6 mm (0.236 in) of the conductor insulation on the cores.
- Prepare the conductor ends of stranded and finely stranded conductors: use a suitable crimping tool to fasten wire end ferrules. Connection cross-sections: 0.5-2.5 mm<sup>2</sup> (21-14 AWG)
- Release terminals.
- Insert conductor.
- Tighten terminals to a maximum torque of 0.7 Nm.

Terminal assignment: see the following page

**NOTICE**

- Care must be taken when mounting the PS point sensor that the electrodes are clean and free from grease. This is achieved by cleaning with methylated spirits or a household detergent with fat solvent.
- The mounting and installation instructions for the SCR sensor cable must be observed. ([www.bartec.de](http://www.bartec.de))

**Commissioning**

A suitable overcurrent protection mechanism must be provided in the power supply of the device and labelled with the name of the device. This also serves as a separator, for all poles, and must be easily reachable for the user.

**NOTICE**

Loss of function due to incorrect procedure.

- All maintenance and troubleshooting work may only be carried out by authorised qualified personnel.
- Directive 2014/35/EU must be taken into consideration.

Check the following before commissioning:

- Device has been correctly installed.
- Device is undamaged.
- Connection has been carried out correctly (check that the cores are secure).

Care must be taken when mounting the PS point sensor that the electrodes are clean and free from grease. This is achieved by cleaning with methylated spirits or a household detergent with fat solvent.

**NOTE**

Water leakages are detected quickly in accordance with the volume and the conductivity of the leaked liquid. The SCR sensor cable has the shortest reaction time with at least a complete point by point cover (approx. 5 mm). For reasons of its geometry, the PS point sensor requires the leaked liquid to have a minimum height (see the PS point sensor data sheet for details).

Design measures must be introduced to keep conductive substances that are not to be detected away from the sensor (e.g. rainwater, splashing water, condensate etc.).

**NOTICE**

The presentation of a correctly prepared and completed acceptance report is essential for warranty claims. This must include date and signature.

**Leakage test**

- Immerse the PS point sensor approx. 5mm or the SCR sensor cable approx. 10 cm in the expected leaked liquid (or water).
  - The 'Alarm' LED lights up after approx. 10 secs
  - Buzzer is active and floating contact switches
  - Dry the PS point sensor or SCR sensor cable
  - Press 'RESET' button
  - 'Operation' LED lights up
- System is in monitoring mode

**Open circuit test**

- Briefly remove the terminal resistance on the last PS point sensor or at the end of the SCR sensor cable and then reconnect it
  - 'Break' LED lights up
  - Buzzer is active and floating contact switches
  - Press 'RESET' button
  - 'Operation' LED lights up
- System is in monitoring mode

**Sensitivity**

The sensitivity of the sensor can be influenced in two different ways:

- a) "Sensitivity" potentiometer on the front of the enclosure
- b) "Termination resistance" selector switch on the side wall of the enclosure must be set to the termination resistance on the end of the sensor. Factory setting: 220 kΩ

**Transport, storage**

**NOTICE**

Damage to the device caused by incorrect transport or incorrect storage.

- Transport and storage only permitted in the original packaging.

**Maintenance and troubleshooting**  
**Water detection system**

**DANGER**

Disconnect the device from the power supply before work on the wiring.

The company operating the device must maintain it in a proper condition, operate it correctly, monitor it and clean it regularly.

The PS point sensor and SCR sensor cable themselves are maintenance-free.

- Care must be taken when mounting the PS point sensor that the electrodes are clean and free from grease
- By means of suitable inspection intervals in line with the degree of contamination or the amount of dust to be expected, it is necessary to ensure that the electrodes of the PS point sensor and of the SCR the sensor cable are kept clean and free from grease. This is achieved by cleaning with methylated spirits or a household detergent with fat solvent.
- Plug-in connections on the installation route must be installed so that they are protected against moisture. When monitoring surfaces, the customer should use spacers on the floor for this purpose.

A recurring inspection of the monitoring electronics is fundamentally not necessary because the electronics are self-monitoring.

**NOTICE**

BARTEC recommends a system inspection at least once a year. The countermeasures introduced when detecting a leak must be adjusted in terms of weighting and reaction speed to the damage to be averted. The operator must clarify insurance requirements (building, liability etc.), for example inspection intervals, scope of inspections, training of the operating staff.

**WARNING**

Serious accidents due to damaged components.

- Inspect the device and cables regularly for cracks, damage and to check that connections are secure.

**NOTICE**

Damage to the device due to incorrect cleaning.

- Do not use compressed air to clean soiled RDA01 monitoring electronics.

**Troubleshooting**

**WARNING**

Serious accidents due to the failure to use original spare parts.

- Only replace parts with original parts.

Faulty devices can be repaired. They must be replaced in line with these Operating Instructions.

**Accessories, spare parts**

**NOTE**

The monitoring electronics require a terminal resistance (05-0080-0164) in the last PS point sensor (factory installed) or at the end of the SCR sensor cable.

See the BARTEC catalogue for further accessories and spare parts.

**Disposal**

The components of the BARTEC water detection system contain metal and plastic parts.

Statutory requirements for electronic waste must therefore be complied with during disposal (e.g. disposal by an approved disposal company).

**Service Address**

BARTEC GmbH  
Max-Eyth-Str. 16  
97980 Bad Mergentheim  
Germany  
Phone: +49 7931 597 0  
info@bartec.de  
www.bartec.de

**Terminal assignment**

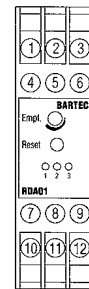

**Connection/Function**

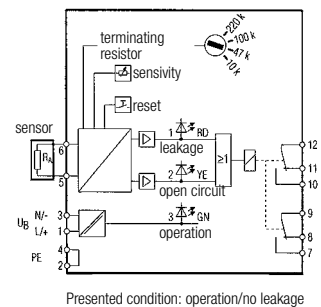

**Dimensions in mm**

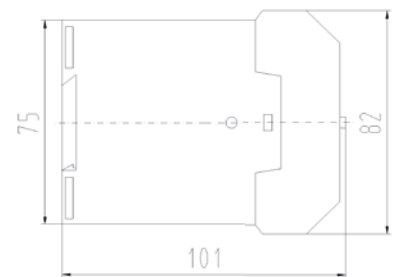

Module wide: 22.5 mm

**Technical data**

Achievement	Snap-on housing for mounting rail TS 35
Dimensions (W x H x D)	22.5 mm x 82 mm x 101 mm
Inputs	power supply Type 2322: AC 230 V/50 to 60 Hz/2.4 VA Type 2422: DC 24 V/0.6 W  sensor via two-wire lead sensor cable length: max. 1 000 m point sensors: max. 50 pcs.
Outputs	common alarm relay, 2 changeover contacts 0.25 A at AC 230 V/1 A at DC 24 V
Memory	alarm/fail safe memory
Method of measurement	conductive (conductive liquids > 2 µS/cm)
Self-monitoring	sensor rupture and power failure
Operating elements	reset button
Signal	optical: LED-displays for operation/alarm/open circuit acoustic: piezoelectric buzzer
Ambient temperature	-25 °C to +60 °C
Protection class	IP 20
Signal	alarm: LED red (1), open circuit: LED yellow (2), operation: LED green (3)

**Technical data** plug/socket

Wire gauge	0.25 mm <sup>2</sup> /0.75 mm <sup>2</sup>
Cable outlet	Pg 7, max. 6 mm
Dimensions	max. length 60 mm, max. Ø 20 mm
Material of shell	PA
Flammability acc. UL-94	V-2
Operating temperature	- 40 °C to + 85 °C

**Assembly instruction**

Plug/socket for connection cable and SCR sensor cable:

Connection Sensor cable	plug/socket	connection splicing
Wire white with perforation	terminal 1	wire 1
Wire white	terminal 2	wire 2
Wire red with perforation	terminal 3	wire 3
Wire red	terminal 4	wire 4

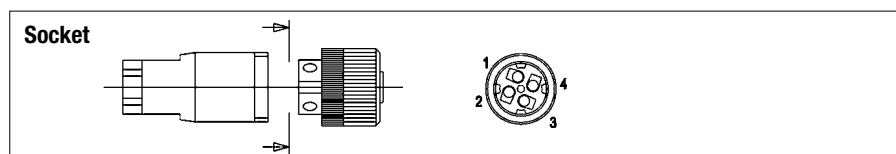
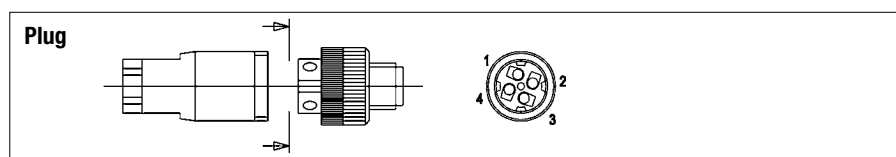
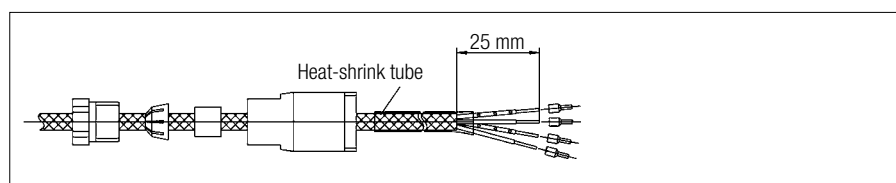

EU Konformitätserklärung  
 EU Declaration of Conformity  
 Déclaration UE de conformité

**BARTEC**

BARTEC GmbH  
 Max-Eyth-Straße 16  
 97980 Bad Mergentheim  
 Germany

N<sup>o</sup> 11-85F4-7C0001

Wir	We	Nous
<b>BARTEC GmbH,</b>		
erklären in alleiniger Verantwortung, dass die Produkte	declare under our sole responsibility that the products	attestons sous notre seule responsabilité que les produits
<b>Überwachungselektronik RDA01, RDW03</b>	<b>Electronic monitoring RDA01, RDW03</b>	<b>Electronique de supervision RDA01, RDW03</b>
<b>17-85F4-2***/*, 17-85F3-8322/*</b>		
auf die sich diese Erklärung bezieht den Anforderungen der folgenden <b>Richtlinien (RL)</b> entsprechen	to which this declaration relates is in accordance with the provision of the following <b>directives (D)</b>	se réfèrents à cette attestation correspond aux dispositions des <b>directives (D)</b> suivantes
<b>NS-Richtlinie 2014/35/EU</b>	<b>LV -Directive 2014/53/EU</b>	<b>Directive BT 2014/53/UE</b>
<b>EMV-Richtlinie 2014/30/EU</b>	<b>EMC-Directive 2014/30/EU</b>	<b>Directive CEM 2014/30/UE</b>
<b>RoHS-Richtlinie 2011/65/EU</b>	<b>RoHS-Directive 2011/65/EU</b>	<b>Directive RoHS 2011/65/UE</b>
und mit folgenden Normen oder normativen Dokumenten übereinstimmen	and is in conformity with the following standards or other normative documents	et sont conformes aux normes ou documents normatifs ci-dessous
<b>EN 61010-1:2010</b> <b>EN 60335-1:2012</b> <b>EN 60529:1991 +A1:2000</b> <b>+ A2:2013</b>	<b>EN 61000-6-2:2005</b> <b>EN 61000-3-2:2014</b> <b>EN 61000-3-3:2013</b> <b>EN 61000-6-3 :2007 + A1:2011 +</b> <b>AC:2012</b>	
<b>Verfahren der internen Fertigungskontrolle</b>	<b>Procedure of internal control of production</b>	<b>Procédure de contrôle interne de fabrication</b>
<b>CE</b>		
Bad Mergentheim, den 12.02.2018		
 i.V. Michael Wittmann Produktmanagement Wärmetechnik	 i.V. Gitta Kugler Director Global Test, Certification & IP Management	



Customer \_\_\_\_\_

Commission number \_\_\_\_\_

Project \_\_\_\_\_

Building \_\_\_\_\_

Item	Installed cable length in metres	Measured insulation resistance in MΩ between conductors 1 and 3 before installation	Measured insulation resistance in MΩ between conductors 1 and 3 after installation*	Measured insulation resistance in MΩ between conductor 1 to ground		Volume resistance in Ω between conductors 1 and 2 conductors 3 and 4*		Calculated volume resistance in Ω/m**	Date of test/test engineer
				conductor 1	conductor 3	conductor 1 and 2	conductor 3 and 4		
1									
2									
3									
4									

\* (measured with end plug), measurement section: sensor cable with incoming feed line  
 \*\* (measured resistance of conductors 1 and 3 in Ω/installed cable length = calculated resistance in Ω/m)

- Conductor 1 = contact 1 = wire white with perforation
- Conductor 2 = contact 2 = wire white insulated
- Conductor 3 = contact 3 = wire red with perforation
- Conductor 4 = contact 4 = wire red insulated

**Note**  
 The sensor cable must be checked during assembly also. When checking, disconnect the sensor cable from the monitoring electronics.

**Test tolerance for the measurements**  
 Volume resistance in Ω: min: 5.7 Ω/m, max: 6.3 Ω/m  
 Insulation resistance in MΩ: not less than 10 MΩ per entire measuring circuit (at a test voltage of 500 V)

\_\_\_\_\_  
 Stamp/signature of installation company

All warranty claims are subject to the submission of a correctly and completely filled-in acceptance report.  
 Date and signature are also required.



**Start-up protocol WaterWarningSystem**

<b>Customer/final customer</b>	
<b>Order number</b>	
<b>Date</b>	
<b>Monitoring unit</b> type, production number	
<b>Software version</b>	
<b>Incoming cable</b> type, length	
<b>Connected sensor 1</b> type, length, room	
<b>Connected sensor 2</b> type, length, room	
<b>Others</b>	

**Function test**

Alarm/leakage test	
Rupture test	
Floating alarm contacts	
Floating fault contacts	
Internal buzzer	

**Note**

**Result**

After execution of the tests/measurements the system operated with/without insufficiencies and restrictions (see notes).

Above information checked:

Place, date Company/signature auditor Company/customer signature

All warranty claims are subject to the submission of a correctly and completely filled in acceptance report.  
Date and signature are also required.

**Service Address**

BARTEC GmbH  
 Max-Eyth-Str. 16  
 97980 Bad Mergentheim  
 Germany  
 Phone: +49 7931 597 0  
 info@barte.de  
 www.bartec.de

11-85F4-7D0001-01/2018-EHT-320192

**Reservation** Technical data subject to change without notice. Changes, errors and misprints may not be used as a basis for any claim for damages.