



- Universal power supply
- Sensor monitoring
- Can be used in conjunction with Pt100 Ex, for temperature regulation in explosion-protected heating circuits

The DPC_{front} temperature control device series consists of three standardised temperature control devices that are adapted to the (trace) heating applications. Having two 7-segment displays, the operator can read both set- and measured temperature at first sight. By pressing a single button, the controllers power output is displayed, allowing an evaluate of the heating circuits quality. The control devices can act as ON/OFF or PID control devices. If desired, the autotuning function will automatically determine the optimum (PID) adjusting parameters for the control path. In all models the regulation can be switched off for maintenance work by pressing a single button. On account of the wide-range voltage input the devices can be used almost everywhere in the world.

DPC_{front} Standard	Pre-parameterisation as ON/OFF controller Also usable as a PID controller Pt100, mV standard signals, thermocouples
DPC_{front} Komfort	Pre-parameterisation as a PID controller Also usable as ON/OFF controller Pt100, mV standard signals, thermocouples Process-value feedback through 4 to 20 mA analog output
DPC_{front} Monitor	Pre-parameterisation as a PID controller Heating current monitoring Universal measuring input Process-value feedback through 4 to 20 mA analog output RS485 interface/Modbus RTU

Assembly

The control device is mounted into the front panel. The compact dimensions of the front (48 x 48 mm) allow a space-saving control cabinet design. The electrical connection is set up through terminal screws on the rear.

Function

Temperature alterations in the sensor are evaluated in the DPC_{front} and shown as temperature readings on the top LED display. If the reading falls short of or exceeds the temperature value that can be seen in the bottom LED display, the output being used will automatically switch itself on or off to set the manipulated variable to the required value. To monitor the temperature, a high & low alarm function is pre-programmed. The devices detect malfunctioning at the sensor and in the control circuit and report these as faults. Each type of alarm is signalled as a group alarm via a relay.

Technical data

Operating temperature range	0 °C to +50 °C
Storage temperature	-10 °C to +60 °C
Dimensions (L x W x D)	48 mm x 48 mm x 108 mm
Installation	Front panel (Cut-out 45.5 mm x 45.5 mm)
Weight	180 g
Protection class	IP 54 or IP 65 with installation sealing
Terminals	Terminal screws 2 x 1.5 mm ²
Enclosure material	Plastic UL 94 V0

Electrical data

Nominal voltage	AC 100 V to AC 240 V +/- 10 % 50/60 Hz
-----------------	---



- Process-value feedback by 4 to 20 mA analog output
- Logic output for SSR
- Universal measuring input
- Modbus RTU
- Very good measuring accuracy

The DPC_{front} Monitor temperature control device is designed as a control device with special functions: heating current monitoring, external setpoint switching and communication through RS 485. It works in the factory setting as a PID control device with a logic output and a relay output. As an alternative, the same device can also be used as a ON/OFF control device. The device is used to regulate a logic output for solid state relays. The relay output is used for alarm signalling. In addition a digital input can be used to choose between different setpoints. The high and low alarm function, sensor monitoring, heating circuit monitoring and heating current monitoring offer additional safety for temperature regulation. When using the device with the factory setting, a simple setup is used for putting into operation for the first time. For example the setpoint, analog output limits, heating currents, low alarm, and if desired, the high alarm must be set.

Technical data

Control characteristics	PID or ON/OFF
Sensor input	Pt 100, NTC, PTC Standard signals 4 to 20 mA; 0/1 to 5 V, 0/2 to 10 V Standard signals 0 to 50 mV, 0 to 60 mV, 12 to 60 mV Thermocouple J, K, S (etc.)
Input impedance	at 4 to 20 mA 51 Ω, at mV 1 MΩ
Input impedance	depending on the sensor version
Measuring accuracy with resistance thermometers	± 0.15 % of actual value or ± 1 °C, the higher value applies ± 1 digit
with thermocouples	± 0.15 % of actual value or ± 1 °C, the higher value applies ± 1 digit (see in addition reference junction accuracy)
at standard signals	± 0.15 % of actual value ± 1 digit
Accuracy of reference junction with thermocouple measurements	0.04 °C for each °C of the control device's operating temperature (20 min. of the control device's operating time)
Sampling frequency at the sensor input	7.5 Hz
Current transformer input	max. 50 mA
Digital input	on-floating, i. e. floating contact required
Output 1	Logic output for SSR control (DC 20 V/20 mA)
Output 2	Analog output 4 to 20 mA, maximum load: 300 Ω
Output 3	Relay output 1 normally open contact (5 A - AC 1, 250 V)
Output auxiliary supply	DC 12 V/max. 20 mA
Electrical service life of the relay outputs	At least 100.000 switching cycles
Interface	RS485 (optically isolated)
Kommunikation protocol	Modbus RTU
Transmission speed	1200 to 38400 bauds

Protection class	II
Power consumption	max. 9 VA (depending on connection of outputs)
Weight	0.2 kg

Circuit diagram

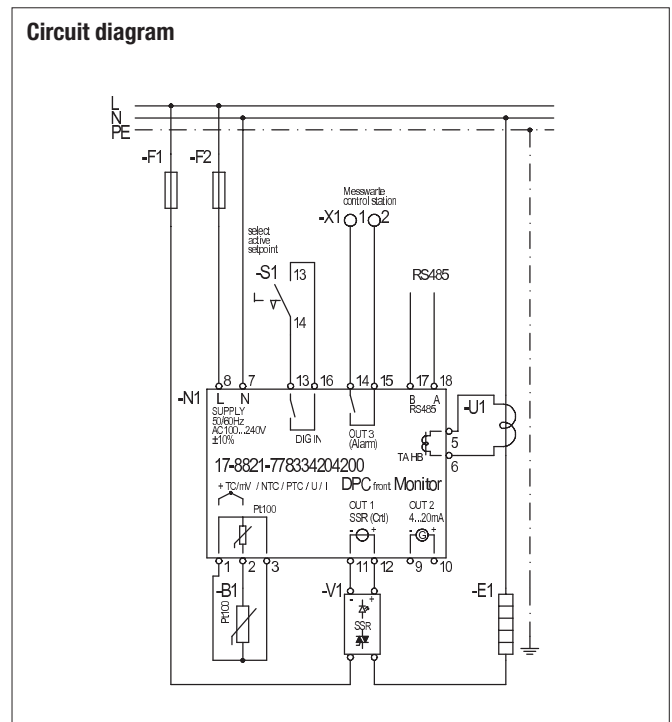

Ordering information

DPC_{front} Monitor **17-8821-7783/34204200**

Technical data subject to change without notice.