



## Protective conductor terminals and PE terminals

### Description

Electrical equipment with operating voltages of more than 65 Volt need protective conductors. Metal enclosures also need an external protective conductor connection.

BARTEC supplies these connections in three different sizes. The connections correspond to VDE 0170 and carry marking  $\perp$  or  $\oplus$ .

### Installation instructions (A):

Push in square cap (do not hammer in); put on terminal clamp and fasten screw with spring washer. Screw type terminals with U-brackets have to be wired according to EN 60999-1; 2000.

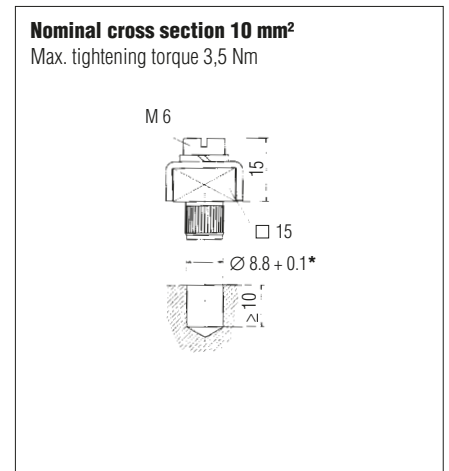
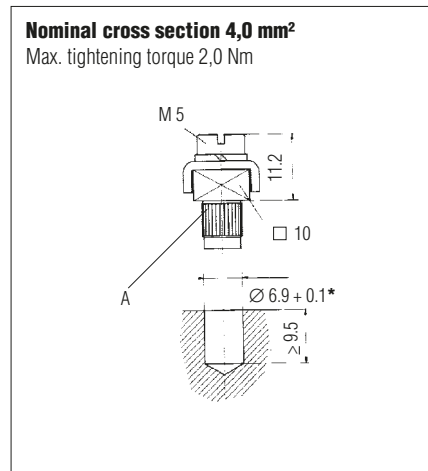
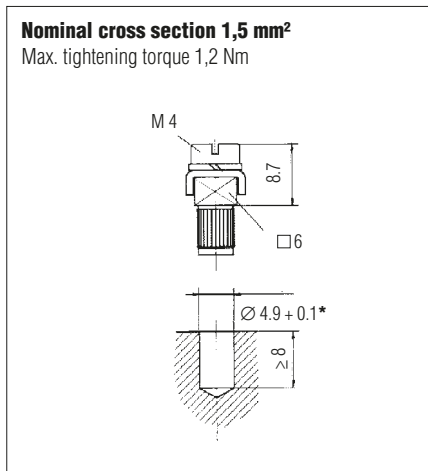

\*Hole diameter in case of aluminium

### Selection chart

|  | Name            | Nominal cross section | Possible conductors   | Socket material  | ➔ Order no.         |
|--|-----------------|-----------------------|---|------------------|---------------------|
|  | Earth terminals | 1.5 mm <sup>2</sup>   | 1.5 mm <sup>2</sup> stranded, 2.5 mm <sup>2</sup> single wire   | Ms nickel-plated | <b>05-0012-0038</b> |
|  |                 | 4.0 mm <sup>2</sup>   | 4.0 mm <sup>2</sup> stranded, 6.0 mm <sup>2</sup> single wire   | Ms nickel-plated | <b>05-0012-0001</b> |
|  |                 | 10.0 mm <sup>2</sup>  | 10.0 mm <sup>2</sup> stranded, 10.0 mm <sup>2</sup> single wire | Ms nickel-plated | <b>05-0012-0003</b> |
|  |                 | 1.5 mm <sup>2</sup>   | 1.5 mm <sup>2</sup> stranded, 2.5 mm <sup>2</sup> single wire   | Niro steel       | <b>05-0012-0039</b> |
|  |                 | 4.0 mm <sup>2</sup>   | 4.0 mm <sup>2</sup> stranded, 6.0 mm <sup>2</sup> single wire   | Niro steel       | <b>05-0012-0018</b> |
|  |                 | 10.0 mm <sup>2</sup>  | 10.0 mm <sup>2</sup> stranded, 10.0 mm <sup>2</sup> single wire | Niro steel       | <b>05-0012-0022</b> |
|  | PE terminals    | 1.5 mm <sup>2</sup>   | 1.5 mm <sup>2</sup> stranded, 2.5 mm <sup>2</sup> single wire   | Ms nickel-plated | <b>05-0012-0002</b> |
|  |                 | 4.0 mm <sup>2</sup>   | 4.0 mm <sup>2</sup> stranded, 6.0 mm <sup>2</sup> single wire   | Ms nickel-plated | <b>05-0012-0034</b> |
|  |                 | 10.0 mm <sup>2</sup>  | 10.0 mm <sup>2</sup> stranded, 10.0 mm <sup>2</sup> single wire | Ms nickel-plated | <b>05-0012-0035</b> |
|  |                 | 1.5 mm <sup>2</sup>   | 1.5 mm <sup>2</sup> stranded, 2.5 mm <sup>2</sup> single wire   | Niro steel       | <b>05-0012-0019</b> |
|  |                 | 4.0 mm <sup>2</sup>   | 4.0 mm <sup>2</sup> stranded, 6.0 mm <sup>2</sup> single wire   | Niro steel       | <b>05-0012-0036</b> |
|  |                 | 10.0 mm <sup>2</sup>  | 10.0 mm <sup>2</sup> stranded, 10.0 mm <sup>2</sup> single wire | Niro steel       | <b>05-0012-0037</b> |