

Motor Purge Controller MPC

High temperature

Features

- Automatically functioning Ex px purge system for electric motors
- Fail-safe control – SIL 2
- Purging/operation status display

Description

The motor purge control system consisting of an MPC Motor Purge Controller and an MPV Motor Purge Valve (outlet valve) is a unit which allows the safe operation of electric motors in hazardous environments.

The explosion protection is ensured by means of a pressurised enclosure with leakage loss compensation.

The Motor Purge Control System monitors, controls and regulates the supply of purge gas to the Ex p motor.

Any faults that arise within the system or during the supply of purge gas will be reliably reported and deactivated by a safe disconnection of the Ex p motor.

Dimensions

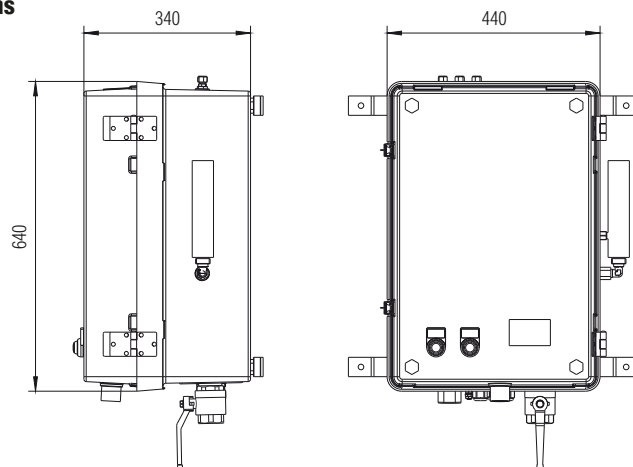



Explosion protection

Ex protection type Zone 1

ATEX II 2(1)G Ex de [ia Ga px] IIC T4 Gb

Certification

DMT 99 ATEX E 082

IECEX Ex de [ia Ga px] IIC T4 Gb

Certification

IECEX BVS 13.0039

Ex protection type Zone 2

ATEX II 3G Ex nA nC [ic pz] IIC T4 Gc

Further approvals

see BARTEC Internet: www.bartec-group.com

Ambient temperature

-30 °C to +50 °C

Directives

2004/108/EC

94/9/EC

Electrical data

Supply voltage

AC 230 V (AC 115 V) ± 10 %

Power consumption

P = approx. 25 W/AC 230 V

Signal contacts

Enabling contact K2/3

(Ex p operation)

K2/3, 5A at $\cos \phi = 1$, non-floating

Signal contact K4 (purging operation)

floating, 500 mA at AC 250 V/DC 80 V

Signal contact K5

(switching level freely assignable)

floating, 500 mA at AC 250 V/DC 80 V

Technical data

Construction

inside the protective housing

Varnish

RAL 7032

Enclosure material

Polyester (glass-fibre-reinforced)

Protection class

IP 65

Connection terminals

2.5 mm²

Pressure measuring range

0 to 25 mbar

Purge time

0 to 99 minutes (settable)

Supply of purge gas

Inlet

R 1" internal thread MPC S2

R 1 1/2" internal thread MPC S3

Outlet

R 1" internal thread

Signal lines

3 x pipe connection 10 mm

Flow rate

0 to 180 m³ MPC S2

0 to 450 m³ MPC S3

Leakage compensation

0.05 l/s to 11.5 l/s

Selection chart MPC for Zone 1

Description	Supply voltage	Code no.	Variant	Code no.
System MPC HT	AC 230 V	1	MPC S2	2
	AC 115 V	2	MPC S3	3

Complete order no. 07-3711-6210/ M 7

Please enter code number. Technical data subject to change without notice.

Selection chart MPC for Zone 2

Description	Supply voltage	Code no.	Variant	Code no.
System MPC HT	AC 230 V	1	MPC S2	2
	AC 115 V	2	MPC S3	3

Complete order no. A7-3711-6110/ M 7

Please enter code number. Technical data subject to change without notice.