



Washer for milk sampling bottles

6858-1 Series A

Operating instruction

BA 020624

	Contents	Page	Date of issue
1	Machine description	1-1	
1.1	Task	1-1	
1.2	Construction	1-1	
1.3	Function	1-2	
1.4	Control	1-4	
1.5	Technical data	1-5	
2	Safety requirements	2-1	
3	Installation	3-1	
3.1	Location	3-1	
3.2	Cable connections	3-1	
3.3	Control of proportioners	3-3	
4	Operation	4-1	
4.1	Operating elements and displays	4-1	
4.2	User instructions	4-4	
4.3	Put washer into operation	4-4	
4.4	Operating mode	4-6	
4.4.1	Operating mode "Automatic"	4-7	
4.4.1.1	Setting options in the automatic operation	4-8	
4.4.1.2	Start automatic operation	4-9	
4.4.2	Operating mode "Manual"	4-10	
4.4.2.1	Function selection	4-10	
4.4.3	Operating mode "setup"	4-11	
4.4.3.1	Setting "Magazine 2 full"	4-12	
4.4.3.2	Setting "Barcode fields"	4-12	
4.4.3.3	Setting "Pump washer empty"	4-13	
4.4.3.4	Setting "Preservation"	4-14	
4.4.3.5	Setting "Destopper-set"	4-15	
4.4.3.6	Setting "Dry-run"	4-15	
4.4.3.7	Setting "Initialize barcode reader"	4-16	
4.4.3.8	Setting "Throughput counter"	4-16	
4.4.4	Service	4-17	
4.4.4.1	Service - monitor mode	4-17	
4.4.4.2	Service – Switch to input/output test	4-18	
4.4.4.3	Service – Software version	4-18	
4.4.4.4	Service – Total throughput counter	4-18	
4.5	Input/output test	4-19	
4.5.1	Selection of input module	4-19	
4.5.2	Selection of output	4-20	
4.6	Messages	4-21	
4.6.1	Fault messages	4-21	
4.6.2	System status messages	4-21	
4.6.3	Magazine 2 full	4-21	
4.6.3.1	Drive washer empty / pump washer empty READY	4-22	
5	Maintenance	5-1	
5.1	Daily maintenance after work	5-1	
5.2	Weekly maintenance	5-2	
6	Fault clearance	6-1	
6.1	Fuses	6-1	
6.2	Performance check	6-3	

7	Tables	7-1
7.1	Manual functions	7-1
7.2	Inputs	7-2
7.3	Outputs	7-4
7.4	Fault messages	7-5
7.5	System status messages	7-9

*All rights and changes reserved.
Neither the whole document nor any part of it may be reproduced
or transmitted in any form or by any means
without the express written permission of BARTEC.*

Copyright © 2002 by
BARTEC GmbH
Schulstraße 30
D-94239 Gotteszell

Document: BA 020324
Revision: Series A
Author: Martin Santl
Translation: Evi Bauernfeind

Valid as from: 04.02
Updated: 18.04.2002
Date: 24.06.2002

1 Machine description

This operating instruction applies to the washer type 6858-1. Due to a different software update or a different configuration, the operating steps or screen displays described here may deviate slightly from those of your appliance.

1.1 Task

The washer type 6858-1 has been designed for the fully automatic (nearly sterile) cleaning of milk sampling bottles of the type 6845. Depending on the equipment of the washer, apart from washing, rinsing and drying, each bottle can be also treated with liquid and solid (tablet) preservative agents. The performance of the unit comprises the sorting-out of sample bottles with unreadable barcode tags and the optional automatic stoppering of cleaned bottles.

1.2 Construction

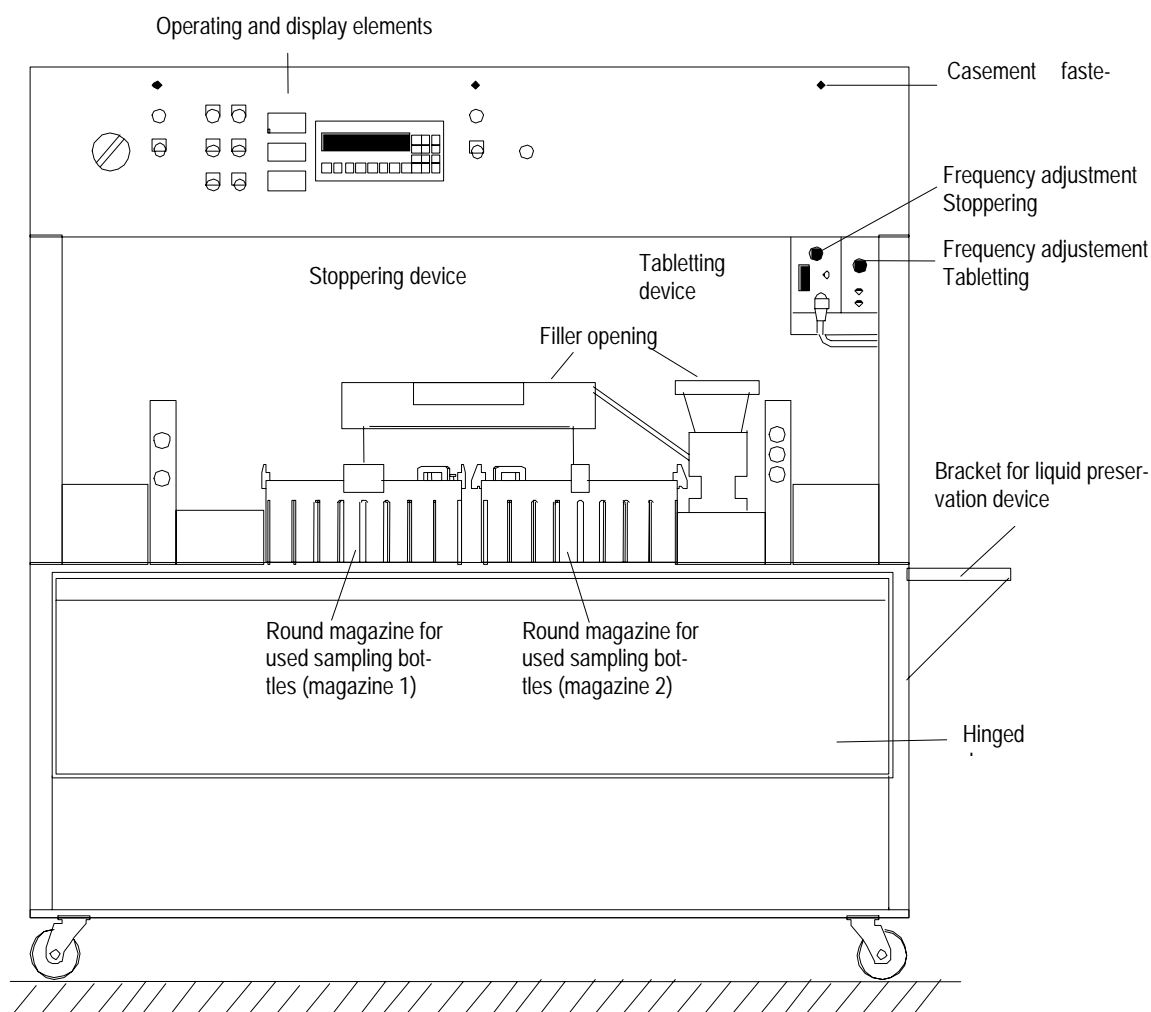

1.3 Function

At the destopper-set station (accessory equipment), the used bottles from round magazine 1 are opened and transported to the push-down device. The push-down device transports the stopper-free bottles to a magnetic tape. The magnetic tape transports the sampling bottles with their opening downwards, in rows of six, through the individual processing zones. The process begins with the emptying of the bottles in the drain zone. In the subsequent pre-wash zone, a detergent is sprayed out of a nozzle plate into the interior and onto the outer walls of several rows of sampling bottles at the same time. In the main wash zone, lances are driven into the sampling bottles and clean them with a detergent solution that is about 55°C hot, either alkaline or acid. The outer walls are also sprayed by means of nozzles here. The subsequent final rinse zone rinses the bottles with water from the final rinse zone in the first cycle, and in the second rinse cycle with fresh water mixed with rinse aid. To terminate the cleaning process, the bottles are blown out with hot air (70°C) in the drying zone.

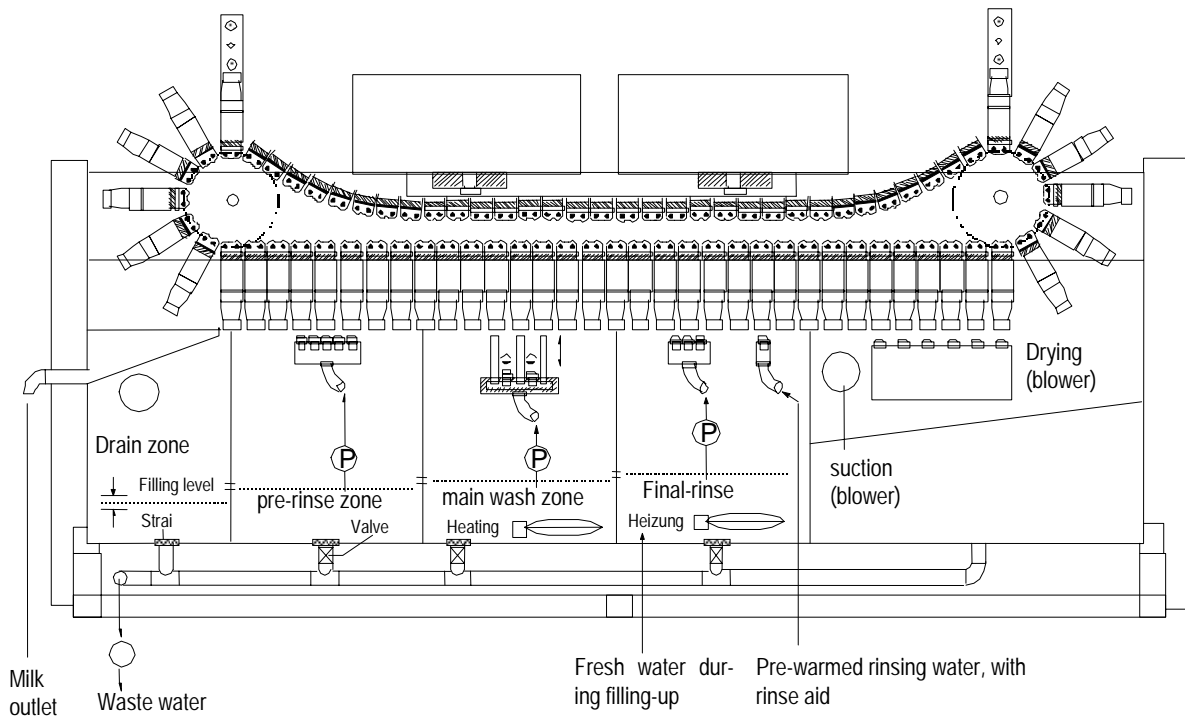

After the bottles have run through the cleaning zones, the magnetic tape transports the cleaned bottles to the top of the washer again. A push-up device moves the sampling bottles one after another from the magnetic tape onto a rotary platform for the bar code reading. Sampling bottles whose tags can be read and whose barcode is within the adjustable barcode field (up to 5) are counted.

Depending on the equipment and the selected washing program, these readable bottles undergo a solid (tablet) or a liquid preservation and are closed with a stopper. Sampling bottles that have not been read or whose barcode is beyond the pre-set field are neither preserved nor closed with a stopper nor pushed into magazine 2, but are pushed further. When the appropriate number has been reached, the panel display shows a message.

Detergents and rinse aids are added automatically during the washing program. For this reason, the detergent concentration in the main wash zone is controlled by means of a conductivity measurement. The constant fresh water supply in the rinse zone, level compensation due to openings between the individual zones, and the level-dependent draining in the drain zone grant a continuous renewal of the cleaning fluid.

The detergent and the rinse agent are pumped into the washer out of separate hoppers. Stoppers and preservation pills have to be poured into the appropriate funnel openings of the washer. The operator puts the round magazines on hexagonal pivots and aligns them on centre cones.

The throughput time of the cleaning plant corresponds to a performance of 1000 sampling bottles per hour. This performance is reduced by the time required for replacing the round magazines.

The washing operation requires decalcified water (degree of hardness 0...2). If necessary, a water softener has to be connected ahead.

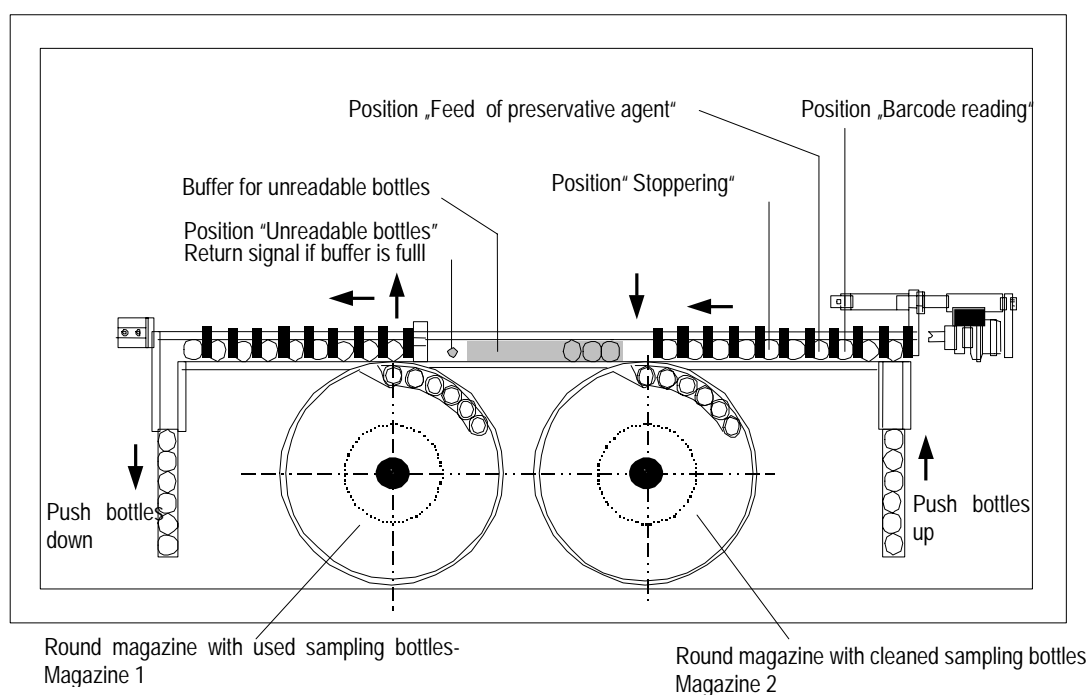

1.4 Control

A freely programmable control runs and monitors the washing process. Six washing programs can be entered via the keyboard of the operating panel. The corresponding display shows the current program number.

The temperatures in the main wash zone and in the final rinse zone as well as the drying temperature are monitored, regulated and displayed. For this purpose, three temperature modules are situated next to the operating panel.

The sampling bottle counter stops the cleaning process as soon as the pre-set number of sampling bottles has entered the round magazine (setting: 1...99, one magazine has a capacity of 70 sampling bottles). If the filling is set to 0 bottles, the monitoring is deactivated and the washer can be run without magazine 2. Make sure that the bottles are taken out continuously.

After a password has been entered, the control makes possible to switch over to manual operation. In this operating mode, each function of the washer can be carried out separately.

For the preserving and stoppering device, adjusting elements have been installed; on these adjusting elements, the vibration frequency of the respective feed container can be changed and the feed can be regulated. If there is a fault at the stopper feed or at the preservative agent feed, the bottle transport is stopped.

To use a liquid preservative agent, the user can supplement the washer by a proportioner (e.g. "dispenser"); for this purpose, a bracket has been mounted at the right side of the washer. The injection of the liquid preservative agent is carried out at the same time and at the same place as the tableting process.

After a washing program has been selected in the automatic mode, the cleaning zones are filled with fresh water and detergent. In a parallel process, the blowers for drying and suction start. After the filling process has been completed, the heating-up of the wash zones starts. After about 25 minutes, the washer is ready for operation.

1.5 Technical data

Electrical data	
Operating voltage	400 V / 50 Hz, 3 phases
Internal power supply	plug socket AC 230 V, 16 A (for liquid preservation)
Total performance	approx. 10 kW
Protection	16 A per phase
Cable connection	5 m connection cable with plug CEE/ 5x 16 A
Ambient conditions	
Permissible operat. temperature	0...40 °C
Permissible storage temperature	0...+60 °C
Climatic classification	KWF according to DIN 40040
Water supply	
Cold water	softened 0...2°dH(= German hardness degree), approx. 10°C flow rate max: 100 l/h, hose connection for 1/2"
Waste water	hose connection for 3/4", via lye pump max. 3bar; max. rise of the sewer:0.5m
Hose connection for wetting agent	for hose $\varnothing_{\text{inside}} = 6 \text{ mm}$
Hose connection for acid detergent	for hose $\varnothing_{\text{inside}} = 6 \text{ mm}$
Hose connection for alkaline detergent	for hose $\varnothing_{\text{inside}} = 6 \text{ mm}$
Compressed air	
Pressure	4...6 bar
Air throughput	300 l/h
Connection	Rico quick lock, nominal bore 7.2
Exhaust air	max. 1.5m ³ /min, 300 Pa, approx. 50 °C, approx. 90% relative humidity/DIN65; exhaust air socket: \varnothing 60mm. (on the appliance: pipe \varnothing 100 mm, corrosion resistant and dehydrated)
Process temperatures	
Washing temperature	50...60°C, factory-set
Drying temperature	max. 70°C, factory-set
Rinsing temperature	approx. 40 °C (pre-rinse) approx. 50...60 °C (final rinse with rinse aid)
Washing performance	
Throughput	1000 bottles / h *
Throughput time	approx. 25 min.*
	* The specified data apply to an operation without interruption (without faults and replacement of round magazines or similar)
Design	
Construction	Mobile stainless steel frame with table superstructure
Milk outlet	HT-pipe, \varnothing 50mm
Weight	
Protection typee	IP 54
Volume	approx. 1800 x 1820 x 1000 mm (width x height x depth)

1-6

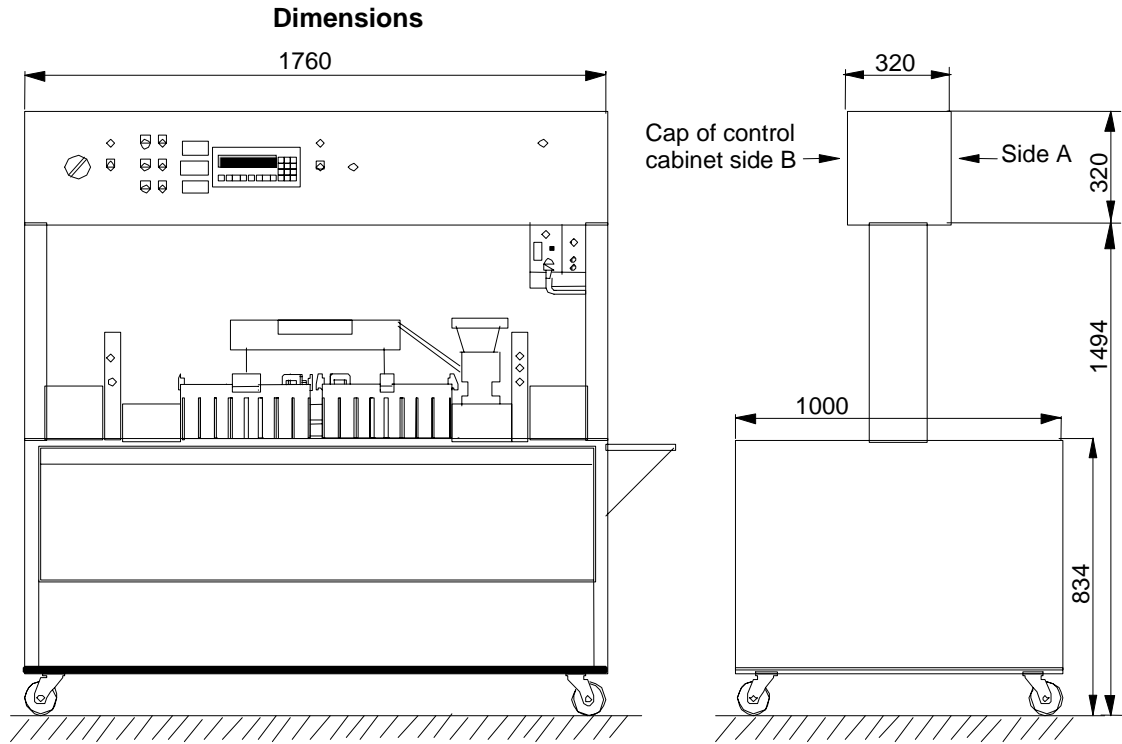

2 Safety requirements

The appliances have been built conforming to the statutory regulations and, after having been thoroughly checked, have left the factory in an irreproachable condition.

- The appliances have to be installed and maintained by skilled staff.
- Make sure that the data and operating conditions specified by BARTEC are complied with.
- Before installing the device and putting it into service, please read the operating instruction. If you have any questions on certain issues, you will get detailed information by our staff.
- Before connecting the supply voltage, make sure that the operating voltage of the appliance conforms with the mains voltage.
- Switch off the washer immediately and protect it from being switched on again if there is any risk that it can't be operated without danger any more (e.g. if there are visible damages).
- Relieve the support rollers during transport. The rollers only serve to position the washer.



Before carrying out maintenance or cleaning work, disconnect the washer from the mains supply!

Disclaimer

In principle, BARTEC Componenten und Systeme and their auxiliary persons are only liable for damages caused deliberately or by gross negligence. The extent of liability is restricted to the value of the order placed with BARTEC Componenten und Systeme. BARTEC will not be responsible for any damages resulting from the fact that safety instructions aren't observed or that the operating instruction or the operating conditions are disregarded. There is no liability for consequential damages.

3 Installation



- When installing the washer, please stick to the common safety regulations.
At all events observe the safety instructions specified in chapter 2.
- Observe by all means the prescribed connecting data.
- Keep to the permissible ambient temperatures.
- Disconnect the washer from the mains supply before connecting or disconnecting any power supply cables.

3.1 Location

Place of installation: level ground area with a maximal permissible inclination of 2°.

When choosing the location for the washer, make sure that the line connections are easily accessible and the position of the milk outlet is appropriate.

3.2 Cable connections

The position of the cable connections is variable. Depending on the local conditions, their position can correspond either to position A or to position B (see illustration). (The milk outlet has a fixed position).

If the water hardness degree is above 2, a water softening device has to be connected ahead of the washer.

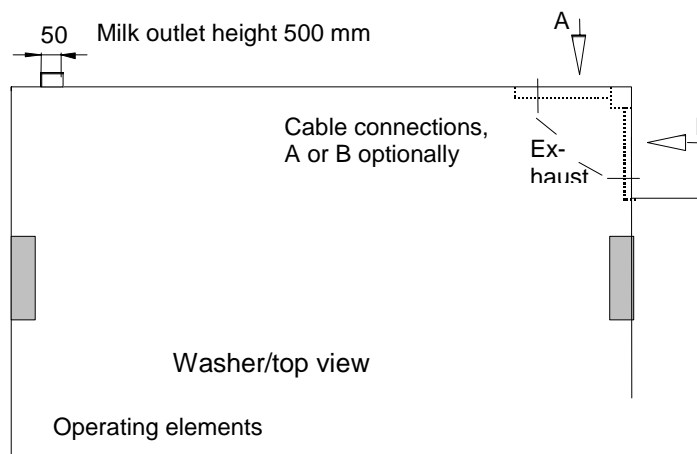

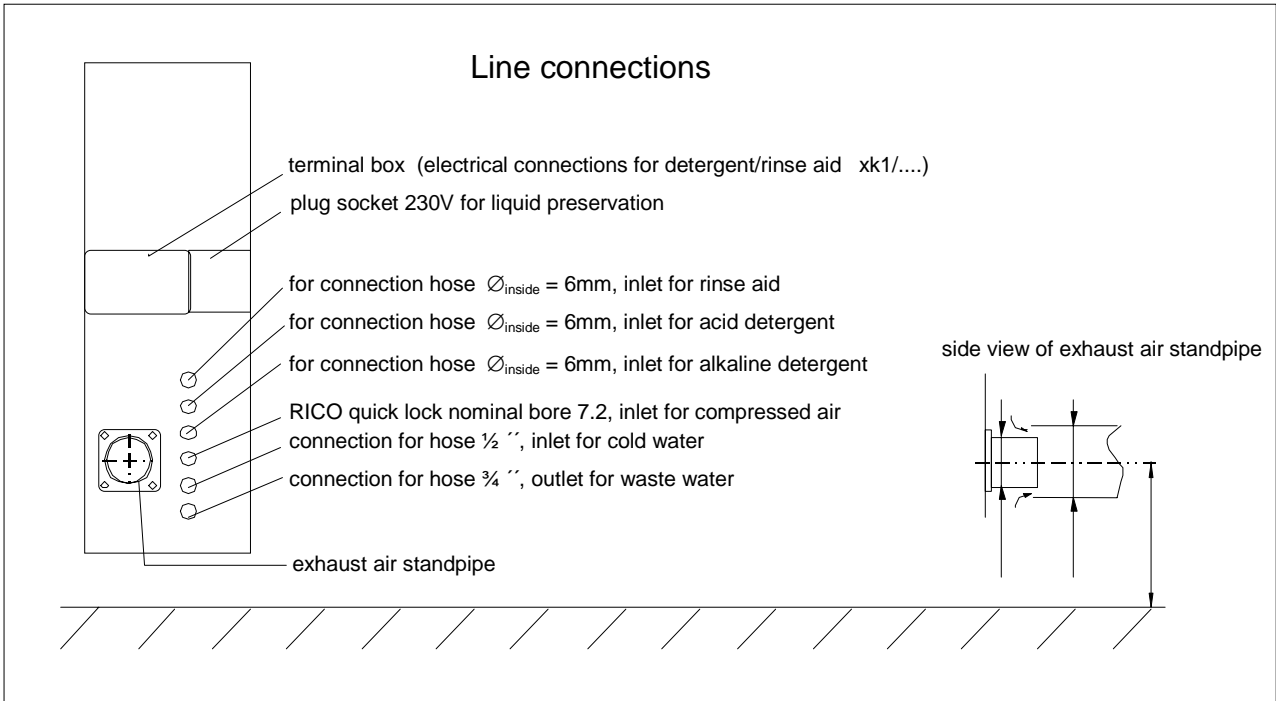

- The individual hoses have to be pushed onto the appropriate connecting nipples and secured by means of hose clamps.

Connecting data:

Inlet compressed air:	4...6 bar, air throughput 300 l/h.
Inlet cold water:	softened, up to 40°C, 0...2 dH (German degree of hardness), max. 100 l/h.
Outlet waste water:	Waste water pressure max. 3bar. Maximum rise 0.5 m.
Outlet exhaust air:	max. 1.5 m ³ /min; 300 Pa; approx. 50 °C; approx. 90% relative humidity (DIN65). If exhaust air is sucked off, make sure that external air can flow in at the exhaust air standpipe.
Electrical connection:	5m connecting cable with plug CEE 16A, 400/230V, 3 phases, 50Hz.

An external shut-off cock has to be installed in the compressed air pipe and in the cold water pipe respectively!

3.3 Control of proportioners

The washer sends return signals to control the supply of rinse aid and detergent as well as impulses for the supply of liquid preservative agents. Furthermore, the filling of an external detergent tank is monitored. For this purpose, the appropriate relay contacts have to be operated in the terminal box (above the line connections).

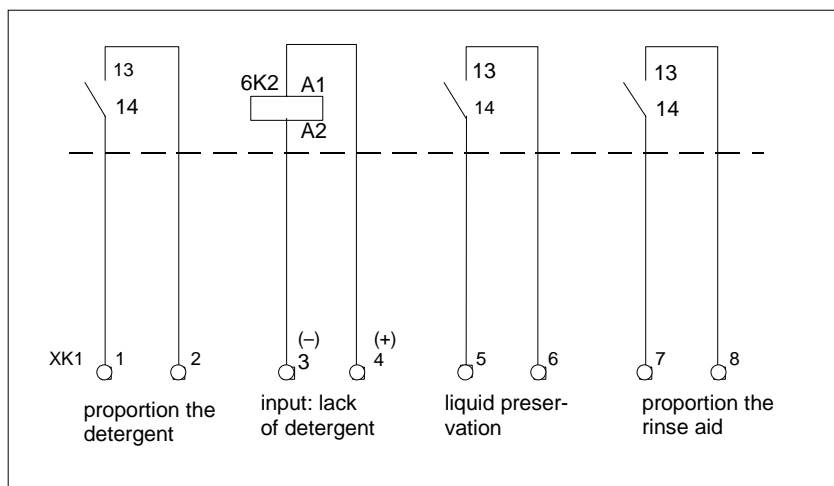

The auxiliary energy supply of the proportioners is independent of the washer.

Limit values:

(connected relay contacts):

$$U_{\max} = 250V \text{ AC/DC}$$

$$I_{\max} = 6 \text{ A}$$

Relay 6K2:

$$U_B = 24V \text{ DC} / 13 \text{ mA}$$

4 Operation

4.1 Operating elements and displays

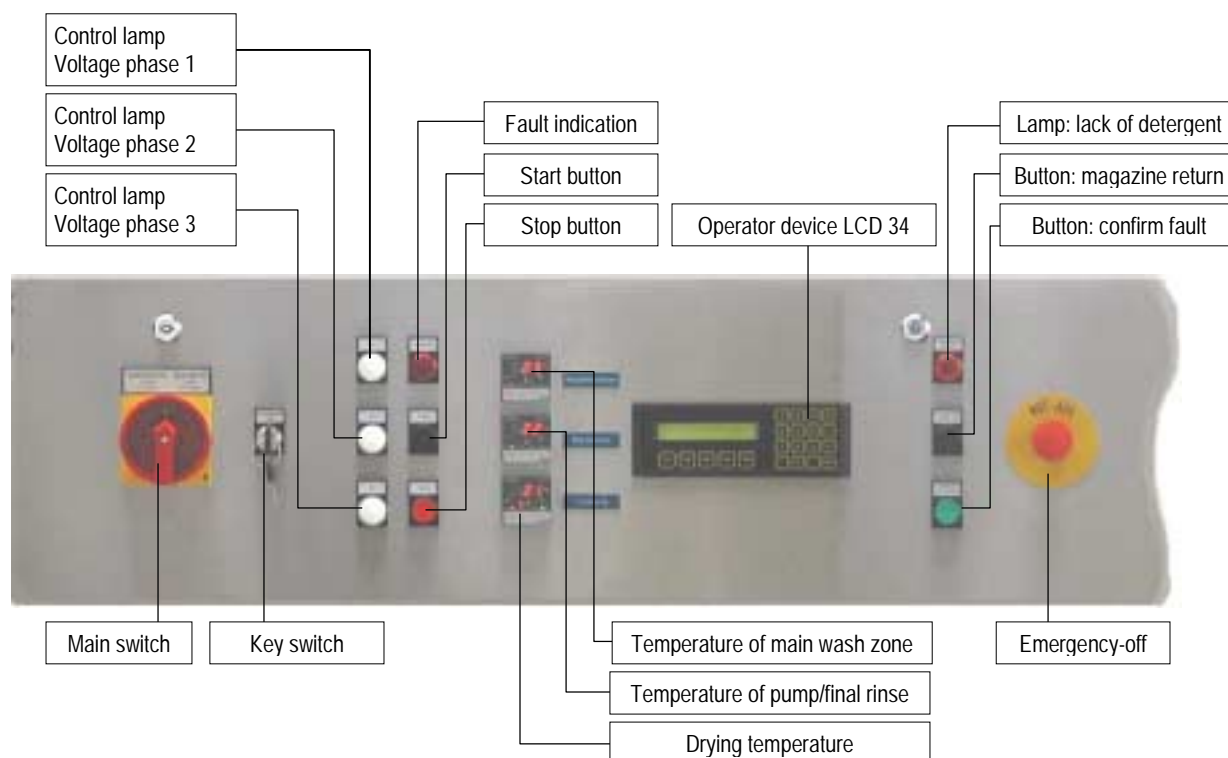

Button <Magazine return>

As long as this button is pushed down, the two drive units of the round magazines 1 and 2 are turned on. Due to this, the magazines that may wedged at the hexagon pusher fingers can be taken out and set in more easily.

Signal lamp „Lack of detergent“

The signal lamp indicates that the detergent concentration in the main wash zone is insufficient. The signal lamp can flash while and immediately after the washer is filled up, as the concentration has to be reached first. If the signal lamp flashes during normal operation – when the main wash zone has been filled up -, you have to check if there is enough detergent. This message is controlled by the conductance regulator and is not evaluated by the control, i.e. there is no message on the display.

Entry and display panel



Keyboard components

[F1]	Automatic operation	} can only be changed in the "operating mode"
[F2]	Manual operation	
[F3]	Setups	
[F4]	Switch on function (ON → installed) or trigger function in manual operation	
[F5]	Funktion abschalten (OFF → not installed)	
[0]...[9]	Numerical entry keys	
[-]	Switch to last message again	
[.]	Without function	
[R]	Back to previous display	
[=]	Enter new value	
[C]	Correct – repeat the entry of a number	
↵	Confirm selection or value entry	

Status information

On each of the function keys [F1] to [F5], there is one LED. These LEDs provide you with information on the operating conditions of the washer. In some cases, additional information texts are displayed.

Status information after the main switch is turned on					
LED [F1]	LED [F2]	LED [F3]	LED [F4]	LED [F5]	Meaning
blinking	OFF/ON	blinking	OFF/ON	blinking	Emergency-off button is pushed
ON	OFF	ON	OFF	ON	Washer starts up normally (part 1)
ON	ON	ON	ON	ON	Washer starts up normally (part 2)

Status information during operation (in the "operating mode" menu)			
LED [F1]	LED [F2]	LED [F3]	Meaning
blinking	OFF	OFF	Automatic operation is selected (confirm with <input type="checkbox"/>)
OFF	blinking	OFF	Manual operation is selected (confirm with <input type="checkbox"/>)
OFF	OFF	blinking	Settings are selected (confirm with <input type="checkbox"/>)
OFF	OFF	ON	Service settings are selected (confirm with <input type="checkbox"/>)





Status information during operation			
LED [F1]	LED [F2]	LED [F3]	Meaning
ON	OFF	OFF	Automatic operation
OFF	ON	OFF	Manual operation
OFF	OFF	ON	Setup
ON	ON	ON	Service settings
LED [F4]	LED [F5]	Meaning	
blinking	OFF	Press [F4] to change the displayed status (e.g. from "OFF" to "ON")	
OFF	blinking	Press [F5] to change the displayed status (e.g. from "installed" to "not installed")	
ON	OFF	Manual operation: function is carried out / is active Service: press [F4] to change status („OFF“ → „ON“) Input/output test: selected output ON	
OFF	ON	Manual operation: function finished / ready Service: press [F5] to change status („ON“ → „OFF“) Input/output test: selected output OFF	

4.2 User instructions



If during operation there is a power failure, or the main switch is turned off, or the Emergency-off button is pushed, there may be a data loss within the washer.

In this case it may be necessary to take the bottles off the chain link at the pushing-up device and pushing-down-device.

- The display of the operator device shows within parentheses “()” which keys, apart from the “common ones”, have a (selective) function.
- Within square brackets “[]”, the lower and upper entry limits of a field are shown; e.g. “[1..33]” means that the entered number may be in the field from 1 to 33, including the limit values 1 and 33. Entries beyond this field are not valid and have to be repeated.
- The keys on the operator panel are framed in this text (e.g. [R]). Keys which are beyond the operator panel, are shown within angle brackets in this text (e.g. <Start>).
- In the “Operating mode” menu and the “Washing program” menu, the <Start> key has the same function as the  key. Due to this, the wear of the  key can be kept low. Furthermore, this makes possible a very fast and easy operation, as the washer stores the old settings and in the “operating mode” proposes the “automatic operation” as standard. Therefore, if the washing program doesn’t change and the washer is filled up and the wash zones are heated up, you just have to press the <Start> key twice (starting from the main menu “Operating mode”) to start the washing operation.
- You return to the previous selection by pressing [R]. The lowest level is the “operating mode”, so pressing [R] there has no effect. [R] has no effect when the washer is in “Automatic operation” and a washing program has been started – the washing process is on. In this case you first have to press <Stop> to stop the program before [R] has an effect.
- If you press [-], the last system status message can be shown on the display, provided that there is no fault. The message disappears automatically if you press any key (except [-]) or after a short waiting time.
- System status messages are automatically shown only in “Automatic operation”. 20 seconds after the last key has been pressed, the system status message is displayed. Press any key (except [-]) to return to the original display shown before the message. It is the same if the system status message is not up to date any more. Entries confirmed with  are not interrupted by messages.
- For the function of the F key LEDs (light-emitting diodes), see the previous tables and the description of the appropriate operating step.
- In the individual operating steps you can read whether , [R], [C] and [=] have a function at the entry.
- If an entry is expected, there is a “>” sign before the operator entry.
- For entries, the value last used is displayed as the proposed value in most of the cases.

4.3 Put washer into operation

- First open the external shut-off valves for cold water and compressed air.

All further steps have to be carried out on the operating elements of the washer.

- Put in a full magazine 1 and an empty magazine 2. (Magazine 2 is required at the latest when a bottle is pushed in.)
- Turn the main switch “ON”.

The self-test of the operator device starts. The display shows “LCD 34”... „Version“ etc.; at the same time the LEDs of [F1] to [F5] flash up one after the other. The self-test is finished after few seconds, and the operator device is ready.

The display shows the following message:

Emergency-OFF

LEDs [F1], [F3] and [F5] blink if the Emergency-off button is pushed. In this case, the Emergency-off button has to be unlocked.

If the Emergency-off button is not pushed, the following message is displayed:

**BARTEC GmbH Gotteszell
Version X.XX**

played after turning the device on:

X.XX stands for the version number of the program software.

LEDs [F1], [F3] and [F5] flash.

After a short waiting time, LEDs [F3] and [F5] are turned on, too.

The following message is displayed:

**BARTEC GmbH Gotteszell
Turn on control**

- Turn the key switch right to turn on the control.

Now the main menu – “operating mode” – is displayed, unless there is a fault

**Operating mode (F1-F3)
<F1> Automatic**

(see 7.4).

4.4 Operating mode

Use [F1] to [F5] to select the operating mode.

[F1]	Automatic
[F2]	Manual
[F3]	Setup
[F4]+ [F5]	Service (hidden, is not shown in display)

The "Automatic operation" is always proposed, so that after turning on the washer, returning to "Operating mode" or pressing [F1], the display shows:

Operating mode (F1-F3)
<F1> Automatic

If [F2] has been pressed, the display shows:

Operating mode (F1-F3)
<F2> Manual

If [F3] has been pressed, the display shows:

Operating mode (F1-F3)
<F3> Setup

If [F4] + [F5] have been pressed, the display shows:

Operating mode (F1-F3)
<xx> Service

The operating mode "Service" is only important for service staff. For this reason, there is no reference to it in parentheses.

The operating mode shown in the display is also indicated by the LEDs on the function keys.

Automatic	LED-[F1] blinks
Manual	LED-[F2] blinks
Setup	LED-[F3] blinks
Service	LED-[F1], [F2], [F3] blink

Press or <Start> to select the operating mode that is shown.

From now on, the LED(s) show(s) permanently the selected operating mode until you return to the "operating mode" menu.

Automatic	LED-[F1] on
Manual	LED-[F2] on
Setup	LED-[F3] on
Service	LED-[F1], [F2], [F3] off

4.4.1 Operating mode "Automatic"

After you have selected the operating mode by means of the [F1] key and you have confirmed the entry by means of the  key, the program last used is displayed, e.g.:

**Washing program (1-6)
Liquid preserv. + stopper**

If the display shows

**Washing program (1-6)
1 not installed**

for example a device required for washing program 1 is not activated in the "Setup" menu.

Use [1] to [6] to select the washing program. The selected program is shown in the second line of the display.

Meaning of the washing program numbers

Nr.	Message displayed	Meaning
[1]	Preserv.tablet + stopper	wash, dry, preservation with tablet, close with stopper
[2]	Liquid preserv.+ stopper	wash, dry, liquid preservation, close with stopper
[3]	Tablet only	wash, dry, preservation with tablet, not close
[4]	Liquid preservation only	wash, dry, liquid preservation, not close
[5]	Stopper only	wash, dry, no preservation, close with stopper
[6]	Wash and dry only	wash and dry, no preservation, not close

Press  or <Start> to select the shown program if it is installed.
Press [R] to get back to "Operating mode".

After you have pressed  or <Start> , the washer is filled up und heated up (except for dry-run ON – see 4.4.3.6); the display shows the appropriate message if no key is pressed within the following 20 seconds (see 4.6.2). Furthermore, functions like "fetch stopper" are started. These "background functions" are only deactivated again when an operating mode other than "Automatic" or "Setup" is selected.

If a key is pressed, for example the following message is displayed:

Automatic (1-3) P2 ← selected washing program
Magazine 2 full = 56 (⇒) ← selected setting

If there is no message and no key is pressed for 20 seconds, the display changes:

The strokes after "Automatic" indicate the automatic operation and they

**Automatic /- - / P2
03/70 12345678 ok**

move.

On the lower left side, the filling level of magazine 2 is displayed. After the slash, the pre-set nominal filling value for magazine 2 is shown. If the nominal filling "0" has been entered, "--/--" is shown here.

"123456780 ok" is shown as an example for a barcode that has been read in correctly. This message disappears after a short time.

If no barcode is read, this field stays empty.

If a code is read that is beyond the adjustable fields, the display doesn't show "ok" but "not ok".

Filling level and barcode don't appear if they are not readable or if the checksum is wrong. In this case, there is the message "not readable" or "checksum bad" in the second line.

If the "Automatic operation" is stopped with <Stop> or if another key (other than [=]) is pressed, the display shows the message of the previous example:

Automatic (1-3) P2
Magazine 2 full = 56 (=)

4.4.1.1 Setting options in the automatic operation

After the selection of the washing program, some settings can be made in the "Automatic" operating mode. This is also possible while the washing program is turned on. The settings are identical with the first two settings in the operating mode "setup". The third one, "drive washer empty", exists only here.

Press [1] to check / change the filling for magazine 2

Press [=] to change the value. The subsequent steps are described in the operating mode "setup" (s. 4.4.3.1).

Automatic (1-3) P2
Magazine 2 full = 56 (=)

You can see the number of bottles (56 in this example) magazine 2 is filled with.

Press [2] to check / change the barcode fields

Press [=] to check/change the value and number of the field limits. The further steps are described in the operating mode "setup" (see 4.4.3.2).

The display shows

Automatic (1-3) P2
Barcode fields = 3 (=)

Automatic (1-3) P2
Barcode OFF (=)

or

if 0 fields are pre-set for the monitoring.

Press [3] to drive washer empty
Turn on with [F4].

Automatic (1-3,F4/5) P2
Drive washer empty ON

Turn off with [F5].

Automatic (1-3,F4/5) P2
Drive washer empty OFF

If “drive washer empty” is OFF, LED-F4 blinks additionally. If you press [F4], LED-F5 blinks, the display changes to “drive washer empty” and the washer is driven empty. This process can be turned off prematurely if you press [F5]; bottles are fetched out of magazine 1 again.

If the washer is not interrupted while it is being driven empty, the fields that aren't required any more (pumps, vibration conveyors, heatings,...) are turned off automatically. After the number of steps for a complete bottle cycle (plus reserve steps) has been reached, the drive-empty process and the washing program are terminated automatically; this is shown by a message which has to be confirmed. While the washer is being driven empty, magazine 1 which is not required any more can be removed without a fault message.

4.4.1.2 Start automatic operation

After the washer has been filled up, the wash zones have been heated up and there are no faults, press <Start> to release the “Automatic operation”. If the washer doesn't react, it is most likely that the temperature has not been reached yet. To avoid waiting for the message which is shown after 20 seconds, you can press [-]. If the washer is ready for operation, the message “Ready to operate” is shown. Press <Stop> to stop the “Automatic operation”.

The washer is not heated up and filled up if the dry-run is activated in the “Setup” menu (s. 4.4.3.6.). If there is no fault, you can start the washer immediately then.

It is possible without any problems to leave the automatic mode and return to it later, unless the operating modes “Manual” or “Service” or another washing program is selected. If this rule has been observed, the washer resumes operation where it was interrupted. Changes in the “manual mode” are not always tolerated by the control at the return to the “automatic mode”. It is possible without problems to set the bottle throughput counter on 0 in the “setup” menu during the heating process.

If you don't select the same washing program, all bottles after the barcode reader are pushed onto the track for outsourced bottles and the replacement of magazine 2 is demanded. This prevents bottles with different treatment from coming into the same magazine. It is the same when the washer is restarted (e.g. after emergency-off).

In principle, bottles are sorted out if

- the barcode is checked and is within one of the pre-set fields
- the barcode is checked and is not readable
- the barcode is checked and the checksum is wrong
- a mistake has occurred at the liquid preservation
- a new washing program has been selected or the washer has been turned off (in this case only the bottles after the barcode reader are sorted out)

4.4.2 Operating mode "Manual"

Press [F2] to select an operating mode and press to confirm the entry. A code check follows:

Code

The code is: 1234567

- Use [0] to [9] to enter the code. The entered figures don't appear on the display.
- To repeat the entry, press [C].
- Press to terminate the entry. If the code is correct, the "function selection" follows. If a wrong code has been entered, the program goes back to "operating mode".
- Press [R] to break off the entry and go back to "operating mode".

4.4.2.1 Function selection

Function [1..33]

> 13

In the function selection, a function according to table "Manual functions" (see 7.1) can be selected and carried out. The functions are identical with the ones used in the "Automatic mode". Partly they consist of several work-steps. In the function "push in stopper" for example, two cylinders are active in both directions (forward and back). This is advantageous as the automatic process can be carried out manually. At the same time, all input conditions are checked in order to avoid mistakes as for example a bottle being jammed or the liquid preservation without a bottle. In the case of a mistake, the same messages are displayed as in the automatic mode.

An input/output test where you can control each individual output is included in the operating mode "Service" (4.4.4.2).

- Use [0] to [9] to enter the function.
- To repeat the entry, press [C].
- Press to confirm the function.
- Press [R] to break off the entry and go back to "operating mode". All outputs are set to the starting position for the automatic operation.

Function 8 Destopper bottle

After you press , the display changes (example: no. 8 destopper bottle). If the device is pre-set as “not installed“ in the “setup“ menu, the following message is displayed:

Function 8 not installed

Then the program goes back to the function selection. It is the same for other devices that have not been installed.

- Press [F4] to trigger the function.
- Press [R] to go back to “Function selection“.

The [F5] key – terminate function – is not assigned in this example, as this function automatically returns to the basic position.

It depends on the function whether the [F5] key is assigned; see table “Manual functions“ (7.1).

Some functions run after for a certain time (pumps, blowers). For further information, see the same table.

LED-F4 indicates that the selected function is running and has not been terminated yet.

LED-F5 indicates that the function has been terminated and is ready.

4.4.3 Operating mode “setup“

After you have selected the operating mode with the [F3] key and confirmed the entry with the  key, the last issue that has been selected is displayed. The individual options are shown by the figures within brackets. If you want to change or check the value or carry out the function, press the key indicated within brackets. The relevant key ([F4]/[F5]) to shift between “ON”/“OFF” or “installed”/“not installed“ respectively is shown by the blinking of the appropriate light-emitting diode (LED).

The settings can always be made when the automatic process is stopped. The background functions (heating, blower, ...) go on if the washing program has already been selected.

Press [R] to go back to “operating mode“.

[0] is not assigned.

If you press [0], the display shows

Setup (1-9)

4.4.3.1 Setting "Magazine 2 full"

- Press [1] to check/change the filling of magazine 2

Setup (1-9)
Magazine 2 full = 56 (=)

You can see the number of bottles (56 in this example) magazine 2 is filled with.

- To change the value, press [=] .

Magazine 2 full [0 - 99]
> 56

The last value (56) is proposed.

- Use [0] to [9] to enter a new value.
- Press [C] to correct the entry.
- Press to take over the entry or the proposed value and return to the previous message.
- Press [R] to return to the previous message without taking over the value.

4.4.3.2 Setting "Barcode fields"

- Press [2] to check / change the barcode fields.

The display shows:

Setup (1-9)
Barcode fields = 3 (=)

or, if zero barcode fields have been pre-set for monitoring so far, the display

Setup (1-9)
Barcode OFF (=)

shows:

- Press [=] to change the value or to change / check the field limits.
- Enter the number of fields to be checked.

Barcode fields [0 - 5]
> 3

The last value (e.g. 3) is proposed. This value remains unchanged if the fields are only to be checked.

- Use [0] to [5] to enter a new value.
- Press [C] to correct the entry.
- Press to take over the entry or the proposed value and to go to the field entry if this value is greater than zero.
- Press [R] to return to the previous display without taking over the value.

For the entry of the barcode field(s), the following message is displayed:

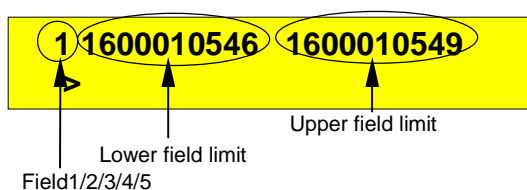

The ">" sign is displayed below the field that can be changed.

The lower limit and the upper limit have to be entered in the right order, i.e. the value of the lower limit mustn't be higher than the value of the upper limit!

Bottles within the entered fields (including the limits) are sorted out.

- Use [0] to [9] to enter the ten-digit barcode. Leading zeros can but needn't be entered.
- Use [=] to shift between the entry of the lower limit and the entry of the upper limit. If a number has been entered, it is taken over.
- If you press both limits displayed in the first line are taken over to the appropriate field. If the field is only to be checked, press to advance to the subsequent fields. After the last field to be checked has been reached, the display returns automatically to "setup".
- Press [C] to correct the entry.
- Press [R] to break off the entry or return to the previous entry.

4.4.3.3 Setting "Pump washer empty"

- Press [3] to pump washer empty
- Press [F4] to turn on the function "pump washer empty"
-

Setup (1-9,F4/5)
Pump washer empty ON

- Press [F5] to turn on the function "pump washer empty" .

Setup (1-9,F4/5)
Pump washer empty OFF

If "pump washer empty " is OFF, LED-F4 blinks additionally. If you press [F4], LED-F5 blinks, the display shows "pump washer empty ON", and the washer is pumped empty. The process can be stopped prematurely if you press [F5]. If the washer is not interrupted during the pump-empty process, the waste water pump is turned off automatically after a pre-set time. This is shown by a message which has to be confirmed.

4.4.3.4 Setting “Washing lances“

- Press [4] to drive washing lances into the bottles
- Press [F4] to turn on the function “washing lances“.

**Setup (1-9,F4/5)
Washing lances ON**

- Press [F5] to turn off the function “ washing lances“.

**Setup (1-9,F4/5)
Washing lances OFF**

If “washing lances“ is ON, LED-F5 blinks additionally. If you press [F5], LED-F4 blinks and the display shows “washing lances OFF“. In normal operation, this function should always be turned on so that the sampling bottles can also be cleaned optimally inside. When this function is ON, the washing lances drive into the sampling bottles when the transport chain is in basic position.

4.4.3.4 Setting “Preservation“

- Press [5] to start preservation

Example: Tablet preservation installed

**Preservation (1-9)
Tablet (=)**

Depending on the washer equipment, the washer can be equipped with a preservation station for solid (tablet) or/and liquid preservative agents. If a device is not selected in this menu, you don’t have access to it in the “washing program“ selection and in the ”function“ selection and it is displayed as “not installed“. If a device that has not been installed is pre-set as “installed“ here and you access to this device, there may be a fault message due to time out, as the device can’t be activated.

- Press [=] to change the setting.
The previous setting is proposed.
- Key [0]

**Preservation (0-3)
> not installed**

No preservation devices installed

- Key [1]

**Preservation(0-3)
> liquid**

Liquid preservation installed

- Key [2]

Preservation (0-3)
> Tablet

Tablet preservation installed

- Key [3]

Peservation (0-3)
> liquid + tablet

Tablet and liquid preservation installed

- Press to take over the setting and return to the previous entry.
- Press [R] to return to the previous entry without taking over the setting.

4.4.3.5 Setting “ Destopper-set“

- Press [6] to activate the destopper-set that automatically removes the stopper
- Press [F4] if it is installed

Destopper-set (1-9,F4/5)
installed

- Press [F5] if it is not installed

Destopper-set (1-9,F4/5)
not installed

If “Destopper-set not installed” is selected, LED-F4 blinks. If you press [F4], LED-F5 blinks and the display changes to “Destopper-set installed“. If this accessory equipment is not installed, you don’t have access to it in the “function” selection and it is displayed as “not installed“. If there is the setting ”installed” though the destopper-set has not been installed and you access to this device, there may be a fault message due to time out, as the device can’t be activated.

4.4.3.6 Setting “Dry-run“

- Press [7] to start the dry-run for testing the washer without water
- Press [F4] to turn on

Setup (1-9,F4/5)
Dry-run ON

- Press [F5] to turn off

Setup (1-9,F4/5)
Dry-run OFF

If the display shows "Dry-run OFF", LED-F4 blinks. If you press [F4], LED-F5 blinks and the display changes to "Dry-run ON". By means of the "Dry-run" function, every washing program can be tested without water. Pumps and heatings as well as blowers remain OFF.

The dry-run is not displayed explicitly in the "automatic mode" and is only reset when the washer is turned on or after an emergency-off.

4.4.3.7 Setting "Initialize barcode reader"

- Press [8] to initialize barcode reader
- Press [F4] to trigger the initializing

**Setting (1-9,F4/5)
Initialize barcode reader**

This function is only required after the barcode reader interface has been replaced. If you press [F4], the interface will beep several times, provided that it is programmed for communication via RS-232 Interface. If the interface doesn't react to the initializing process, you first have to adjust the interface configuration of the barcode reader interface according to the instructions of the manufacturer. This is done by reading in a barcode that sets the interface type to RS-232. Then the interface can be initialized by the SPS.

4.4.3.8 Setting "Throughput counter"

The "throughput" counter registers the total number of bottles washed by the washer, regardless of the fact whether the barcode reading is good or bad. The counter is not monitored by the SPS and can be set back manually. The operator can use it to find out the daily output. The value range is from 0 to 8.388.607.

- Press [9] to see the count of the bottle throughput.

**Setup (1-9, C)
Throughput = 1234567**

Press [C] to set the counter to zero.

4.4.4 Service

If you press , a code check follows

Code

- Use [0] to [9] to enter the code. The entry doesn't appear on the display!
- Press [C] to correct the entry.
- Press  to confirm. If the code is correct, the operating mode "Service" follows. If a wrong code has been entered, the program goes back to "operating mode".
- Press [R] to break off the entry and go back to "operating mode" .

In the service field you have access to settings that require expert knowledge of the washer and the SPS that is used. If the setup is carried out improperly, the device may be put out of service and in the worst case even be damaged.

The code used for the service is different from the code used for "Manual mode", so that the access to the individual fields is reserved to the appropriate persons.

The keys [0] and [5] to [9] are not used at present. If you press one of these keys, the display shows

Service (1-4)

4.4.4.1 Service - monitor mode

- [1] key - monitor mode

The "monitor mode" enables the service staff to have direct access to the memory of the SPS (register and marker) via the operator device. When "monitor mode" is ON, the memory can be manipulated accordingly.

The monitor mode is automatically turned "OFF" when you leave the operating mode "service".

- Press [F4] to turn on monitor mode

Service (1-4) Monitor mode ON

- Press [F5] to turn off monitor mode

Service (1-4) Monitor mode OFF

4.4.4.2 Service – Switch to input/output test

- Press [2] to select the input/output test

Service (1-4)
Input/Output-Test

Press  to start the input/output test. For the description see 4.5.

4.4.4.3 Service – Software version

You see the version number of the SPS software while the washer is running. The version number is also displayed when you turn on the washer (see 4.3)

- [3] key

Service (1-4)
Version x.xx

(x.xx = is a symbol for the version number of the program software)

4.4.4.4 Service – Total throughput counter

The “total throughput“ counter counts the number of all bottles washed by the washer, independent of the result of the barcode reading. The counter is not monitored by the SPS and can't be set back manually. The value range is from 0 to 8.388.607.

- [4] key – count of bottle throughput

Total throughput (1-4)
1234567 bottles

4.5 Input/output test

The texts in the input/output test are in easily understandable English, as the translation into different languages might cause problems because the display has only a restricted character set.

After the function has been selected, the display shows

**Input/Output-Test
(F1=set in, F2=set out)**

4.5.1 Selection of input module

- Press [F1] to select the input module.

**Input module (1-8)
>1**

Each input module has eight inputs. Their allocation can be seen in the table "inputs" (7.2).

- Use [1] to [8] to select the appropriate input module.
- Press [C] to correct the entry.
- Press [↵] to confirm the selection.

Display:

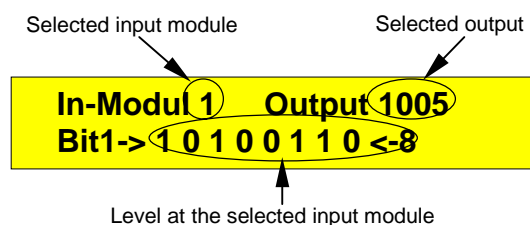

In this example, input module 1 has been selected, with input 101=1, 102=0, 103=1...108=0. The selected output has the address 1005.

The status of the output that appears on the right upper side is displayed by the flashing LED of the keys F4 or F5: LED-F4 = ON, LED-F5 = OFF. Use [F4] and [F5] to change the status of the output.

- Press [F4] to turn on the selected output
- Press [F5] to turn off the selected output
- Press [F1] to switch to the input selection again so that the effect of the selected output on another input module can be observed.
- Press [F2] to switch to the output selection (see 1.4)
- Press [C] to reset all outputs, except the output for the air supply valve
- Press [R] to restart the SPS program and switch to "operating mode" (see 4.4).

4.5.2 Selection of output

- Press [F2] to select an output.

**Output (10x,70x,90x,
100x,110x;x=1-8 >**

The allocation of the outputs can be seen in the table “outputs” (7.3). They have the numbers 101, 102, 103, ..., 108 to 1108 per module, i.e. the entry is three-digit or four-digit.

- Use [0] to [9] to select the output.
- Press [C] to correct the entry.
- Press to confirm the selection.

Display:

**Output 1004
(F4 = on, F5 = off)**

The status of the selected output is shown by the flashing LED of the F4 and F5 keys:: LD-F4 = ON, LED-F5 = OFF.

- Press [F4] to turn on the output
- Press [F5] to turn off the output
- Press [F1] to switch to the SPS input selection (see 4.5.1), where you can observe the effect of the SPS output. The output is switchable there,too.
- Press [F2] to return to the output selection where another output can be changed. Thus, any desired outputs can be set.
- Press [C] to reset all outputs except the output for the air supply valve.
- Press [R] to restart the SPS program and switch to “operating mode“ (see 4.4).

4.6 Messages

There are two main groups of messages: fault messages and system status messages.

Fault messages have a higher priority than system status messages. That means that system status messages are only displayed if there aren't any fault messages.

4.6.1 Fault messages

Fault messages have always to be confirmed. There are different groups of faults. If there are several faults at the same time and these faults belong to different groups, the fault messages are displayed one after another; e.g. there is a group of motors including all drives, pumps and blowers. Another group comprises heatings, pneumatics,...

- A fault message can only be deleted by pressing <Confirm fault> if the fault has been remedied.

If there is a fault message due to time out, it can be confirmed although the fault has not been remedied yet. The fault message is displayed again after the monitoring time has expired.

4.6.2 System status messages

System status messages are only displayed automatically in the operating modes "Automatic" and "Manual".

There are two sorts of system status messages. The first sort is only displayed if within 20 seconds no key has been pressed (except [-]). The other sort is displayed immediately as there is a direct temporal connection between them and the sequence of the function. A common feature of all system status messages is that they disappear as soon as any key is pressed (except [-]). System status messages of the first sort disappear automatically as soon as they are not up to date any more.

Press [-] to display the last message in the operating modes "Automatic" and "Manual".

4.6.3 Magazine 2 full

When the nominal filling of magazine 2 has been reached, the following message is displayed:

**Magazine 2 full
(=, confirm fault)**

- Press [=] to enter a new value (see 4.4.3.1).
- Press <Confirm fault> to confirm the message and to retain the pre-set value.

Examples:

If 42 bottles instead of 37 should be transported into the same magazine 2, the new value has to be entered by means of the [=] key. After the new value has been entered, the magazine is filled with five further bottles.

If it is the next magazine that should be filled with 42 bottles, the "full" magazine has to be removed before the new value is entered. After the new value has been entered, the next magazine is filled with 42 bottles.

If the next magazine should be filled with the same number of bottles, you only have to press <Confirm fault> after the magazine has been replaced.

If the washer should be run without monitoring of the filling level of magazine 2, you have to enter 0. In this case, you have to remove the spiral appliance from the magazine and make sure that the bottles are taken out continuously.

4.6.3.1 Drive washer empty / pump washer empty READY

As soon as the number of steps required for turning off the function "drive washer empty" (4.4.1.1) has been reached or the time required for "pump washer empty" (4.4.3.3) has expired, the appropriate message is displayed:



**Drive washer empty
READY**



**Pump washer empty
READY**

The appropriate message stays on the display until a key is pressed.

5 Maintenance

All bearings in the machine are maintenance-free. They don't need any maintenance.

The inserted gear motors have a lifetime lubrication.

The inserted ventilators are maintenance-free.

The barcode drive motor should be replaced every three months by the service staff (check of the motor drive combination as well as grease renewal at the gearbox).

5.1 Daily maintenance after work

Internal cleaning:

For the internal cleaning, open the hinged door at the front side of the washer.



- Rinse washing chambers (drain zone, pre-wash zone, main wash zone and final rinse zone) with clear water.
- Rinse milk outlet tank (in drain zone) with clear water.
- Remove foreign matters from the washing zones.
- Clean outlet strainers if they are soiled and check if they are fastened (don't run machine without outlet strainers).

External cleaning:

- Table surface – remove milk residues and humidity.
- Transport channel - wipe clean with wet cloth.
- Centrifugal disk of barcode reading station – remove deposits and humidity. This should be done cautiously and carefully because of the cables that are laid there.

5.2 Weekly maintenance

Apart from the daily maintenance, the following works have to be carried out:

- Clean the guide shafts of the bottle pusher station by means of a cloth that contains vaseline (**Z.-Nr: 202993.0010.000/BI.1 Teil-Nr.2**).
- Rub piston rod of the bottle pusher cylinder slightly with vaseline (**Z.-Nr: 202993.0010.000/BI.1** -> piston-rod of the double-acting cylinder with part no. 101).

6 Fault clearance

6.1 Fuses

The automatic fuses and motor protection switches are behind the covering walls on the front side and on the backside (A and B). Each of the covering walls can be folded out after the three casement fasteners have been opened.

Backside



Front side



Fuse	Sicherungskreis
5 FI	Fault current protection switch
5 F1	Detergent proportioner
5 F2	Vibrating conveyor tablets (accessory equipment)
5 F3	Vibrating conveyor stopper
6 F4	Plug socket liquid preservation Clamp XK1 9 (see 3.3 Control of proportioners)
6 F5	Control cabinet ventilator 24VDC supply (SPS)
7 F6	Heating final-rinse zone
7 F7	Heating main wash zone
7 F8	Heating coils/hot air
8 F10	Motor of drying blower/hot air
8 F11	Motor suction blower
8 F12	Pump final-rinse zone
8 F13	Pump main wash zone
8 F14	Pump preliminary clearing/pre-rinse zone
9 F15	Motor chain drive
9 F16	Motor magazine 1
9 F17	Motor magazine 2
9 F18	Pumpe waste water
10 F9	24VDC SPS and inputs
10 F10	24VDC outputs

6.2 Performance check

SPS

Apart from the input/output test, the status of the inputs and outputs can be read directly at the SPS modules. Each SPS module has eight inputs and/or eight outputs. If a LED flashes, 24 V (nominal voltage) are at the input or output. The SPS-CPU Nano, the module N-PS1 and the module N-IO16 have a LED with the label 24V and 5V. Both LEDs have to flash permanently. If the 24V LED is OFF, the outputs are currentless. If the 5V LED is OFF, the internal logic doesn't work. The TX and RX LEDs on module N-Ser 1 indicate a data exchange of the interface.

Barcode reader Interface DLD 1000

The green LED flashes when the interface is supplied with voltage. The red LED always flashes when a barcode has been read in correctly. The reading-in is additionally confirmed by a beep.

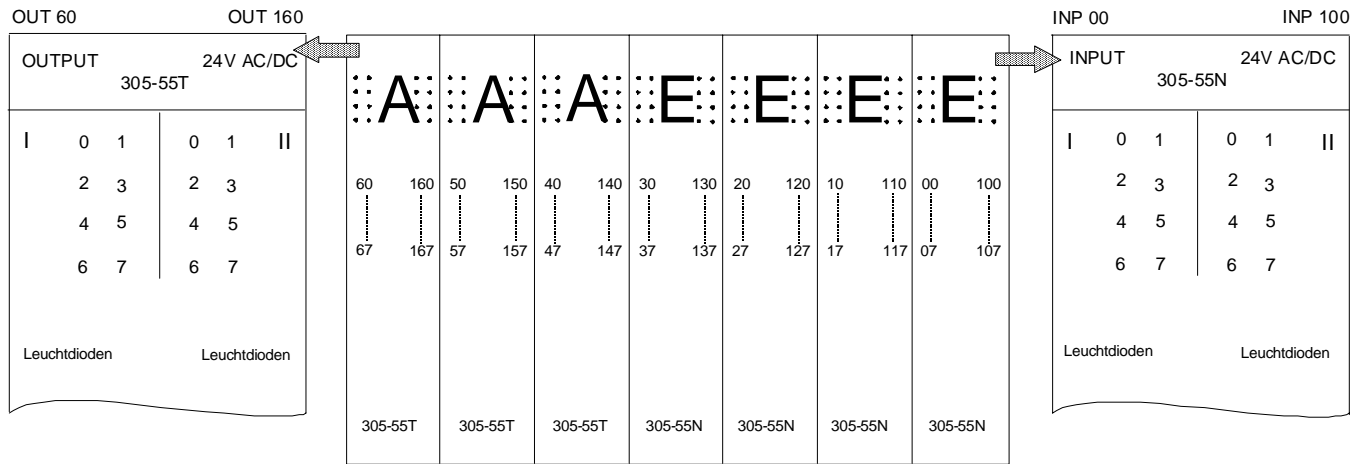

7 Tables

7.1 Manual functions

The numbers to switch to the individual functions in the manual operation, and the appropriate messages on the display are listed below. Press [F4] to activate the function or to turn on the washer. The last column shows whether the [F5] key has an effect on the selected function. Some functions that can only be started by pressing [F4] have a run-after time, e.g. pumps. It is especially important that in the "drying" function, the heater register is immediately turned off if you press [F5]. The blower, on the contrary, has a certain run-after time in order to cool down the heater register.

Nr.	Displayed text (function)	Function key [F5]
1	Magazine 1 forward (turns forward until bottle is ready to be fetched)	none
2	Magazine 1 back (turns back until [F4] and <Magazine return> are not pressed any longer)	none
3	Fetch bottle (brings bottles supplied by magazine 1 into the pusher)	none
4	Drive in pusher (transports the bottles via the pusher fingers to the next position)	none
5	Drive out pusher (drives back pusher fingers to transport the bottles to the next position)	none
6	Pusher fingers forward (swing out pusher fingers; precondition that the pusher can drive in)	none
7	Pusher fingers back (swing in pusher fingers; precondition that pusher can drive out)	None
8	Destopper bottle / not installed (accessory equipment; if installed, it removes the stopper automatically)	none
9	Push down bottle (pushes a bottle supplied by the pusher onto the transport chain)	none
10	Push up bottle (pushes a bottle from the transport chain into the pusher)	none
11	Transport chain next position (the chain drive goes on by one chain link)	none
12	Washing lances in bottle (drive)	Drive washing lances out of bottle
13	Check barcode (the motor of the rotary table starts up, a message informs about the result of the reading process)	none
14	Tablet preservation / not installed (accessory equipment; transports a preservation tablet into the sampling bottle)	none
15	Liquid preservation / not installed (accessory equipment; via a dispenser, liquid preservation agent is brought into the sampling bottle)	none
16	Fetch stopper (fetches a stopper supplied by the vibrating conveyor)	keine
17	Push in stopper (closes sampling bottles with a stopper)	none
18	Push in bottle (pushes bottle into magazine 2)	none
19	Magazine 2 forward (turns forward as long as [F4] is pressed)	none
20	Magazine 2 back (turns back until [F4] and <Magazine return> aren't pressed any longer)	none
21	Pump pre-rinse zone (turn on)	Turn off

Nr.	Displayed text (function)	Function key [F5]
22	Pump main wash zone (turn on)	Turn off
23	Pump final-rinse zone (turn on)	Turn off
24	Pump waste water (after starting the function, the pump runs after for a short time and then turns off automatically)	none
25	Valve final-rinse zone (opens the inlet for the water mixed with rinse aid ; runs after for a short time)	none
26	Fill up valve (opens frees water supply, but only if at least one level has been under-run; runs after for a short time)	None
27	Valve waste water (open)	Close
28	Heating main wash zone (turn on)	Turn off
29	Heating final-rinse zone (turn on)	Turn off
30	Heating drying (turn on)	Turn off
31	Suction blower (turn on)	Turn off / blower runs after
32	Vibrating conveyor tablet / not installed (accessory equipment; after starting of the function, it runs after for a short time and then turns off automatically)	none
33	Vibrating conveyor stopper (after starting of the function, it runs after for a short time and then turns off automatically)	none

7.2 Inputs

Module	Channel	Address	Denomination
1	1	101	Emergency-off is pressed
	2	102	Control is ON
	3	103	Key for program start
	4	104	Key for program stop
	5	105	Confirm fault
	6	106	Key for cassette return
	7	107	Reserve
	8	108	Reserve
2	1	201	/Fault at accessory equipment
	2	202	/Fault at heating
	3	203	/Temperature of rinse zone ok
	4	204	/Temperature of wash zone ok
	5	205	Lack of detergent wetting agent
	6	206	/Fault at motors
	7	207	Door switch is closed
	8	208	Pneumatic pressure ok
3	1	301	Final-rinse zone min. level
	2	302	Main wash zone min. level
	3	303	Flow rate monitor water supply
	4	304	Overflow tank max. level
	5	305	Pre-rinse zone min. level
	6	306	Stopper still available

Module	Channel	Address	Denomination
	7	307	Magazine 1 available
	8	308	Magazine 2 available
4	1	401	Push down bottle here
	2	402	Destopper bottle here
	3	403	Stopper bottle here
	4	404	Magazine of bad bottles full
	5	405	Fetch bottle from magazine
	6	406	Bottle there, pos. push up
	7	407	Stopper available
	8	408	Reserve
5	1	501	Lances wash zone BACK
	2	502*	Lances wash zone FORWARD (cylinders driven out)
	3	503	Bottles pusher BACK
	4	504*	Bottles pusher FORWARD (cylinders driven out)
	5	505*	Pusher fingers drive swung in
	6	506	Pusher fingers drive swung out
	7	507*	Stopper transport BACK (cylinders driven in)
	8	508	Stopper transport FORWARD
6	1	601	Push up bottles BACK
	2	602*	Push up bottles FORWARD (cylinders driven out)
	3	603*	Push down bottle Pos. BACK (cylinders driven in)
	4	604	Push down bottle pos. 6
	5	605	Push down bottle pos. 5
	6	606	Push down bottle pos. 4
	7	607	Push down bottle pos. 3
	8	608	Push down bottle pos. 2
7	1	701	Push down bottle pos. 1
	2	702*	Push bottle into magazine BACK (cylinders driven in)
	3	703	Push bottle into magazine FORWARD
	4	704*	Fetch bottle from magazine BACK (cylinders driven in)
	5	705	Fetch bottle from magazine FORWARD
	6	706*	Stoppering BACK (cylinders driven in)
	7	707	Stoppering FORWARD
	8	708	Reserve
8	1	801	Destopper-set BACK
	2	802*	Destopper-set FORWARD (cylinders driven out)
	3	803*	Destoppering bottle clamps BACK (cylinders driven in)
	4	804	Destoppering bottle clamps FORWARD
	5	805	Tablet transport ok
	6	806	Preserve bottle here
	7	807	Liquid preservation on
	8	808	Position chain drive

7.3 Outputs

Chan-nell	Address	Denomination
1	101	Motor drying blower
2	102	Motor suction blower
3	103	Pump of final-rinse zone
4	104	Pump of main wash zone
5	105	Pump preliminary clearing
6	106	Motor of chain drive
7	107	Motor of Magazine 1 FORWARD
8	108	Motor of Magazine 1 BACK
1	701	Motor of Magazine 2 FORWARD
2	702	Motor of Magazine 2 BACK
3	703	Waste water pump
4	704	Heating of final-rinse zone
5	705	Heating of main wash zone
6	706	Heater register
7	707	Vibrating conveyor tablets
8	708	Vibrating conveyor stopper
1	901	Liquid preservation
2	902	Rotation drive Barcode
3	903	Supply chain Stop initiator
4	904	Fault lamp
5	905	Vent. Ventilate machine
6	906	Vent. Fill up machine
7	907	Vent. Final-rinse / final-rinse external
8	908	Vent. Lances wash zone BACK
1	1001	Vent. Bottle pusher BACK
2	1002	Vent. Bottle pusher FORWARD
3	1003	Vent. Pusher fingers swing in drive
4	1004	Vent. Pusher fingers swing out drive
5	1005	Vent. Stopper transport FORWARD
6	1006	Vent. Push up bottles BACK
7	1007	Vent. Push up bottles FORWARD
8	1008	Vent. Push down bottles
1	1101	Vent. Push bottles into magazine FORWARD
2	1102	Vent. Fetch bottles from magazine FORWARD
3	1103	Vent. Stoppering FORWARD
4	1104	Vent. Open outlets
5	1105	Vent. Destopper-set BACK
6	1106	Vent. Carrier destopper
7	1107	Vent. Destopper-set bottles jammed FORWARD
8	1108	Vent. Throw in tablets

7.4 Fault messages

Several fault messages can be displayed simultaneously. In the case of faults resulting from time out, apart from the monitoring of compressed air and the pumping-off, only the most current one is displayed. Functions during which a fault due to time out has occurred, can be repeated if you press <Confirm fault>. The program "input/output test" can be used to monitor the input/output signals step by step.

Indication	Reason/remedy	Electrical data
Fault EMERGENCY-OFF	Unlock Emergency-off button	Input 101 at "0" Clamp X24 +5 Clamp X4 1 bis X4 4
Fault Heating	Fuse 7F6 final-rinse zone Fuse 7F7 main wash zone Fuse 7F8 heating coil, hot air	Input 202 at "0" Clamp X24 +2
Fault Motor	Fuse 8F10 drying blower Fuse 8F11 suction blower Fuse 8F12 pump final-rinse zone Fuse 8F13 pump main wash zone Fuse 8F14 pump preliminary clearing (pre-rinse zone) Fuse 9F15 motor chain drive Fuse 9F16 motor magazine 1 Fuse 9F17 motor magazine 2 Fuse 9F18 waste water pump Fuse 10F10 24VDC output	Input 206 at "0" Clamp X24 +6 Relay 10K0 contact 13,14 Fuse 10F10
Fault Accessory equipment	Fuse 5F1 detergent proportioner Fuse 5F2 vibrating conveyor tablets (accessory equipment) Fuse 5F3 vibrating conveyor stopper Fuse 6F4 plug socket liquid preservation (accessory equipment)	Input 201 at "0" Clamp X24 +2
Fault N-SER 1 Transmit buffer full	Turn off and restart washer	Connection between SPS module N-SER 1 and bar- code reader interface is defective
Fault N-SER 1 - xxx -	Turn off and restart washer Contact service and display the status register value (module N-SER 1) xxx	-
Fault Control ON	Signal is interrupted briefly or permanently (after washer has been turned on with <Control ON> key)	Input 102 at "0" Relay 10K0 contact 23,24 Clamp X24 +2
Fault Magazine 1 is missing	Put in magazine 1 or turn on "drive washer empty"	Input 307 at "0" Switch 14S9, type D Clamp X2 9 Clamp X24 +3 / X24 -3
Fault Magazine 2 is missing	Put in magazine 2 or set "Magazine 2 full" on 0 (deactivate monitoring)	Input 308 at "0" Switch 14S10, type D Clamp X2 10 Clamp X24 +3 / X24 -3
Fault stopper still there	Stopper still in sampling bottle Remove stopper manually (accessory equipment)	Input 306 at "1" Switch 14S8, type E Clamp X2 8 Clamp X24 +3 / X24 -3

Tables

7-6

Indication	Reason/remedy	Electrical data
Fault Hinged door open	Hinged door to the wash zones not closed	Input 207 at "0" Switch 13S1, type H Clamp X2 1 Clamp X24 +2 / X24 -2
Buffer for outsorted bottles full	Empty the buffer for bottles with outsorted barcode tag	Input 404 at "1" Switch 15S14, type F Clamp X2 14 Clamp X24 +3 / X24 -3
Faults resulting from time out		
Fault Pump off waste water	Maximum level in the overflow tank has not been under-run within monitoring time Clean drain pipe and / or sensor	Input 304 at "1" Switch 14S6, type E Clamp X24 +3 / X24 -3
Fault Air supply	Nominal pressure not reached within monitoring time or dropped during operation Check air supply (hose, valve)	Input 208 at "0" Switch 13S2, type I Clamp X2 2 Clamp X24 +3 / X24 -3
Fault Fill up washer	After the the filling valve has been opened, no water flow is recognized Check water supply (valve, hose, filter)	
Fault Fetch bottle	Low air pressure, blocking, pusher not in basic position (driven out/swung in) Position "driven in" is not left Position "driven out" is not reached Position "driven in" is not reached again Sensor "fetch bottle" always ON	Input 405 Switch 15S15, typee F Clamp X2 15 Input 704 Switch 18S40, typee A Clamp X2 40 Input 705 Switch 18S41, typee A Clamp X2 41 Clamp X24 +3 / X24 -3
Fault Drive in pusher	Low air pressure, blocking, fields that are concerned are not in basic position (e.g. pusher fingers not swung in,, see table "Inputs") Position „driven in“ (Input 503, Switch 16S21, Type G) Position "driven out" (Input 504, Switch 16S22, Type G) Pusher fingers "swung in" (Input 505, Switch 16S23, Type G) Pusher fingers "swung in" (Input 506, Switch 16S24, Type G)	Input 503 Clamp X2 21 Input 504 Clamp X2 22 Input 505 Clamp X2 23 Input 506 Clamp X2 24 Clamp X24 +3 / X24 -3
Fault Drive out pusher	Cf. Fault drive in pusher	Cf. Fault – Drive in pusher
Fault Pusher fingers forward	Cf. Fault drive in pusher	Cf. Fault – Drive in pusher
Fault Pusher fingers back	vgl. Fault drive in pusher	Cf. Fault – Drive in pusher
Fault Fix bottle drive out	Low air pressure, blocking Position "Destopper-set on top" is not left Position "Destopper-set at the bottom" is not reached	Input 801 Switch 19S45, typee B Clamp X2 45 Input 802 Switch 19S46, typee B Clamp X2 46 Clamp X24 +3 / X24 -3
Fault Drive out carrier destopper-set	Low air pressure, blocking Position „neutral position“ not left Position „active position“ is not reached	Input 803 Switch 19S47, Type A Clamp X2 47 Input 804 Switch 19S48, Type A Clamp X2 48 Clamp X24 +3 / X24 -3

Indication	Reason/remedy	Electrical data
Fault Drive out push down bottle	Low air pressure, blocking Position "driven in" not reached Nominal position 1,2,...6 is not reached	Input 603 - 608 Switch 17S31 - 36, Type G Input 701 Switch 18S37, Type G Clamp X2 31 - 37 Clamp X24 +3 / X24 -3
Fault Drive in push down bottle	Low air pressure, blocking Position "driven in" is not reached	Cf. Fault push down bot- tle drive out
Fault push up bottle drive in	Low air pressure, blocking Position "driven out" not left Position "driven in" is not reached	Input 601 Switch 17S29, type G Clamp X2 29 Input 602 Switch 17S30, Type G Clamp X2 30 Clamp X24 +3 / X24 -3
Fault push up bottle drive out	Low air pressure, blocking Position "driven in" not left Position "driven out" is not reached	vgl. Fault Flasche aufschieben push up ein- fahren drive in
Fault Transport chain	Output 106 always on "0" Output 903 on "0" though there is no fault at push down bottle, push up bottle or transport chain Light barrier is soiled - Input 808 permanently ON	Input 808 Switch 19S52, Type L Output 903 Diode V19/V19.1 Relais 19K4 Contact 13,14 Clamp X2 52 Clamp X24 -3
Fault Washing lances	Low air pressure, blocking Position "driven out" is not left Position "driven in" is not reached	Input 501 Switch 16S19, Type B Clamp X2 19 Input 502 Switch 16S20, Type B Clamp X2 20 Clamp X24 +3 / X24 -3
Fault Liquid preservation	Preservation time too long -> change time, change displacement, change vol- ume Proportioner pump is turned off -> turn on	Input 807 Clamp X2 51
Fault Tablet preservation	No tablets available Light barrier is soiled - Input 805 permanently ON Downpipe is blocked	Input 805 Switch 19S49, Type M Clamp X2 49
Fault stopper Drive in carrier	Low air pressure, blocking Position "driven out" is not left Position "driven in" is not reached	Input 706 Switch 18S42, Type B Clamp X2 42 Input 707 Switch 18S43, Type B Clamp X2 43 Clamp X24 +3 / X24 -3
Fault stopper Drive out carrier	Low air pressure, blocking Position "driven in" is not left Position "driven out" is not reached	Cf. Fault stopper Drive in carrier

Tables

7-8

Indication	Reason/remedy	Electrical data
Fault stopper Drive out transport	Low air pressure, blocking Position "driven in" is not left Position "driven out" is not reached	Input 507 Switch 16S25/26, Type A/B Clamp X2 26 Input 508 Switch 16S27/28, Type A/B Clamp X2 28 Clamp X24 +3 / X24 -3
Fault stopper Drive in transport	Low air pressure, blocking Position "driven out" is not left Position "driven in" is not reached	Cf. Fault stopper Drive out transport
Fault Stopper supply	Within the monitoring time, the vibrating conveyor has transported no stopper to the light barrier (Input 407). Light barrier is permanently on "0" level	Input 407 Switch 15S17, Type C Clamp X2 17 Clamp X24 +3 / X24 -3
Fault Push in bottle	Low air pressure, blocking, psuher not in basic position(driven out/swung in) Position "driven in" is not left Position "driven out" is not reached Position "driven in" is not reached again	Input 702 Switch 18S37, Type A Clamp X2 37 Input 703 Switch 18S38, Type A Clamp X2 38 Clamp X24 +3 / X24 -3

7.5 System status messages

Most of the system status messages are only displayed automatically in the "Automatic operation", provided that no entry has been made for 20 seconds. Press [-] to switch to the last message (again or immediately).

Message	Reason	Elektrical
Rinse aid level min	The external device at Clamp XK1 3,4 (see 3.3 Control proportioners) displays a low filling level	Clamp XK1 3,4 Relay 6K2 Input 205 Clamp X24 +2/ X24 +4/ X24 -4
Level min pre-rinse zone	The filling level of the pre-rinse zone ist below minimum level, the others are ok	Input 305 Switch 14S7, Type E Clamp X24 +3/ X24 -3
Level min main wash zone	The filling level of the main wash zone is below minimum level, the others are ok	Input 302 Switch 14S4, Type K Clamp X24 +3
Level min final-rinse zone	The filling level of the final-rinse zone ist below minimum level, the others are ok	Input 301 Switch 14S3, Type K Clamp X24 +3
Fill up washer	At least two levels are below minimum level	see pre/main/final-rinse zone
Heat up main wash zone	The heating of the main zone is ON	Input 203 Switch 21K21 Clamp X24 +2
Heat up final-rinse zone	The heating of the final-rinse zone isON	Input 205 Switch 21K22 Clamp X24 +2
Heat up washer	The temperature of main and final-rinse zone is below the pre-set threshold value at the temperature regulators	see main/final-rinse zone
Magazine 1 empty (confirm fault)	If within the monitoring time, no bottle can be supplied, the program assumes that the magazine is empty Press <Confirm fault> to repeat the process.	-
Barcode yy/zz xxxxxxxxxx not ok	Meaning yy bottles of zz maximal bottle number in magazine 2 Xxxxxxxx is the 10-digit barcode read in that is within the pre-set field limits The form of output depends on the operating mode	-
Barcode xxxxxxxxxx ok	Like above, but the barcode is beyond the pre-set field limits and the bottle is not sorted out	-
Barcode not readable	No tag Tag soiled/damaged Water drops on the tag or on the barcode reader Barcode reader soiled The form of output depends on the operating mode	-
Barcode checksum bad	The checksum of the barcode read in is not correct The form of output depends on the operating mode	-
Drive washer empty READY	The function "drive washer empty" was terminated automatically	-
Pump washer empty READY	The function "pump washer empty" was terminated automatically	-
Washer ready to operate	The washer is filled up and heated up(again) The washing program can be activated with the <Start> key	-
