

Data Sheet

Magneto-inductive Flow Meter type 6820-x, 6823-x

- **Calibratable precision instrument for measuring the quantity of milk in collection trucks during collection and delivery**
- **Suitable for measuring the volume and flow of electrically conductive liquids in the food industry and other sectors.**
- **High measurement precision unaffected by changes of flow velocity, by changeover from laminar to turbulent flow, by fluctuations of viscosity or conductivity**



The magneto-inductive flow meter type MID 6820/6821/6823 with teflon-coated stainless steel measuring tube and connecting flanges made of stainless steel meets the hygienic requirements of the food industry. Thanks to its compact and rugged construction it can be used for measurement jobs in both stationary and mobile systems.

Application

The MID 6820/6821/6823 is designed for use as a volumetric meter during milk truck collections and deliveries. It can be freely configured to suit country-specific conditions. The MID meets national requirements and has been issued with calibration licences by various countries.

Function

The central measuring element of the volumetric meter is a stainless steel measuring tube positioned in the magnetic field of two coils. When milk or any other electrically conductive liquid flows through the measuring tube, it generates a voltage proportional to its velocity of flow. Volume and flow are calculated from this induction voltage by a microprocessor.

The results are transmitted as a digital output signal via a field bus to a further processing unit. The MID has an analog output and a pulse output in addition to a P-NET port. A model with a three-channel pulse output (no analog output) is also available as an alternative. The microprocessor controls the measurement sequence and the transmission of measured values. It monitors all equipment functions, performs automatic zero point correction and temperature compensation, and permits flow measurement in both directions. The resolution of the volumetric measurement is programmable.

The P-NET interface enables the MID to be integrated in automated systems with bidirectional communication capabilities to higher-order units.

The flow meter is notable for being particularly convenient to assemble and service thanks on the one hand to its modular construction consisting of a counting head, electronic module and terminal box and on the other hand to its compact form and small dimensions. The measuring chamber has no moving parts, making it extremely reliable in operation and wear-proof. The measuring tube is CIP-compatible up to 100 °C.

Microprocessor-controlled, magneto-inductive flow meter

- **Can be configured in many different ways**
- **Models with measuring tubes in the sizes 2", 2,5" and 3"**
- **Volumetric flow up to 2000 l/min**
- **Volumetric measurement with programmable resolution**
- **Pulse/analog output or threechannel pulse output**
- **Serial fieldbus interface (P-NET)**
- **Hygienic stainless steel measuring tube**
- **Meets OIML recommendations concerning measurement systems for liquids other than water**
- **CE coding**
- **Calibration licence for several countries**

Technical Data		
Mechanical data		
Plastic case	PPO Noryle, type of protection IP 64 A	
Measurement tube and electrodes	made of stainless steel AISI 316	
Measurement tube	coated with teflon (FEP)	
Weight	approx. 50 N (5 kg)	
Pipeline connection	via connecting flange	
Connection of MID to the connecting flange	with gasket and clamp	
Connection dimensions	according to ISO 2852	
Ambient conditions		
Admiss. operating temperature	- 10 ... + 50 °C	
Admiss. storage temperature	- 10 ... + 50 °C	
Climatic IWA	acc. to DIN 40040	
Electrical data		
Connections	5 m connection cable, shielded, 10-core, with open ends. PG11 cable bushings, internal screw-type terminals.	
Auxiliary energy	auxiliary voltage	AC 24 V, 50/60 Hz, ± 15 % or DC 24 V ± 15 %
	Power consumption	max. 6 W
Models		
For installation in pipelines of 2", 2,5" or 3"		
Measure data		
Measure medium	milk (electrically conductive liquids)	
	conductivity	min. 1 µS/cm
	temperature	0 ... + 100 °C
	pressure	max. 10 bar
Measure precision	measurement precision ± 0,3 % in the indicated flow range, but not less than 1 % of the smallest measurement volume (depending on the particular calibration licence)	
Max. flow	depending on NW (table)	
Measure range	5 (10) – 100 % of max flow depending on calibration permit	
Minimum quantity	≥ 10 l, depending on calibration licence	
Measured value output		
Pulse output	0 – 1000 Hz volumetric measurement signal for counter indication of the current flow	
3 channel pulse output	as 1 channel pulse output with direction signal and error signal as 2- or 3 channel pulse output	
Analog output	4 ... 20 mA (external source)	
Interface		
Field bus interface (P-NET)	serial, asynchronous,	
Baud rate	76800 bit/s	
Lead length	max. 1200 m	
Device type	340	

Flow velocities

NW	0,6 m/s	1,2 m/s	2,4 m/s	4,8 m/s
2"	4200 l/h	8500 l/h	17000 l/h	30000 l/h
2,5"	7200 l/h	15000 l/h	30000 l/h	60000 l/h
3"	11000 l/h	22000 l/h	44000 l/h	120000 l/h

Dimensions

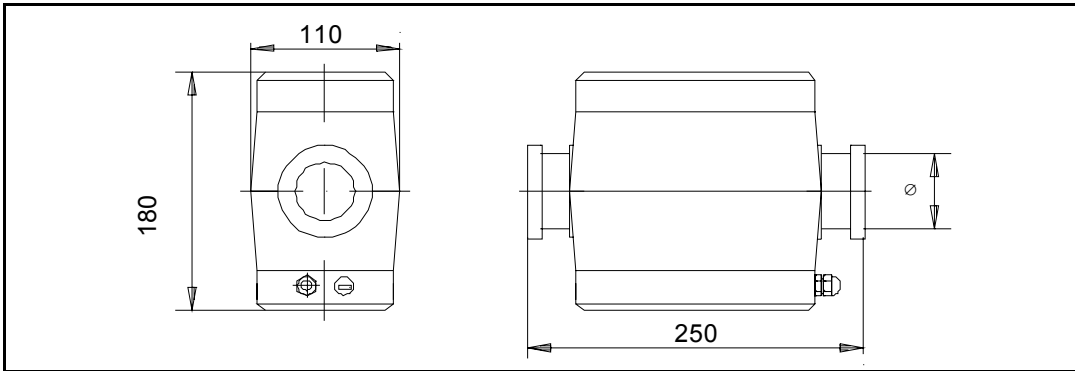

Installation

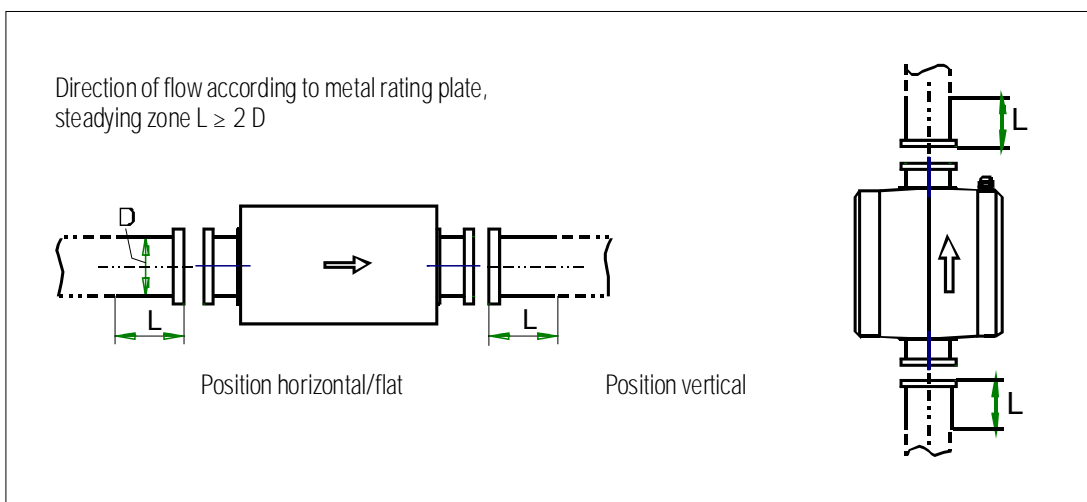

Point of installation	lowest point of the pipesystem, slightly rising to flowdirection.
	position where the MID is always full of liquid.
	point of maximum pressure in the pipeline system.
	following the air separator if there ist any possibility of air being drawn in.
Installation position	horizontal/flat or vertical. operate only with a steadying zone of $L \geq 2 D$ on both sides.

Electical connections

MID with pulse and analog output

Analog output not run via 5 m connecting cable. Assignment of terminals on the MID terminal strip.

Terminal 16: + Pulses

Terminal 17: GND

Terminal 17: GND

Terminal 18: + 4..20 mA

MID-terminal strip 5 m connecting cable

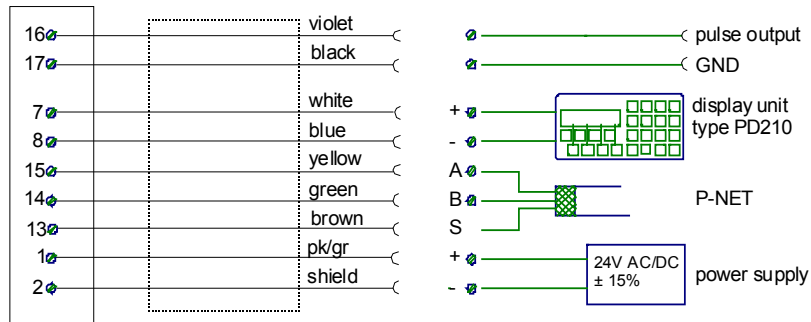

MID with 3 channel pulse output

Circuitry as shown in the table.

Terminals 9, 10, 11, 12 for connecting a Pt100 temperature sensor in accordance with DIN IEC 751.

MID terminal strips

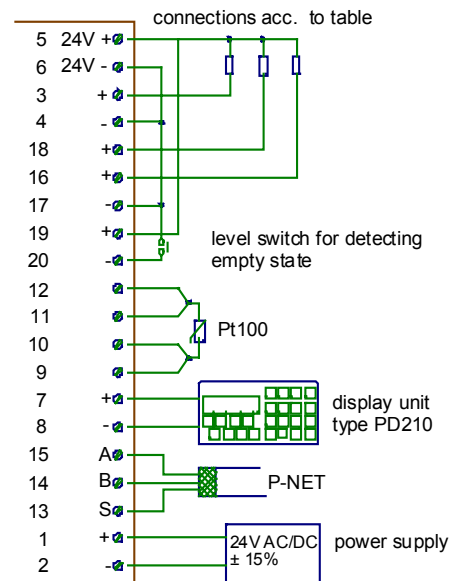
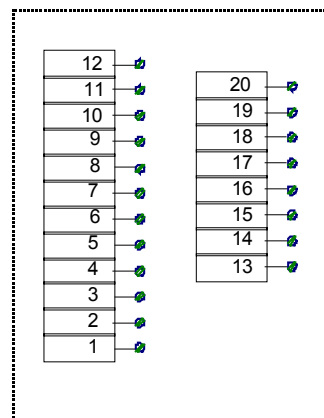

MID (terminal)	1 channel *	2 channel 90°	3 channel 120°
3 – 4	Phase 1	Error	Phase 1
18 – 17	Error	Phase 1	Phase 3
16 – 17	UP/DOWN	Phase 2	Phase 2

* type 6821-14

Approvals

Approvals	A:	E OE90/r120, Nr.ZI.41 598/90	MAK 3001	
		OE95/R340	MAK 3002	
	B:	7703-B-91	MAK 3001	
	CH:	S ZA 125 of 08/87	MAK 3001	
		S 254 of 11/87		
	D:	PTB-Nr. 1.32.6-3265.721-ULT8603		
		Notice 1..4	MAK 3001	
		Notice 5	MAK 3002	
	I:	xx	MAK 3001	
	Irl.:	MIC Cert. 602	MAK 3001	
	NL	Nr. T 1345 of 03/87	MID 6820-2	MAK 3001
		Nr. T 1345/2 of 04/89	MID 6820-3	MAK 3001
NZ:	MCA Cert. 1247		MAK 3001	
	MCA Cert. 1369		MAK 3002	
PL:	NR ZT 650/95		MAK 3001	

MID oder data (with pulse output)

MAK 3001		MAK 3002		Diameter	Flow min.	Flow max.	Min. volume	Certificate	Country
Type	Order number	Type	Order number						
6820-1	950 20 68201	6823-1	950 20 68231	NW 2"	25 l/min	500 l/min	20 l	yes	D
6820-3	950 20 68203	6823-3	950 20 68233	NW 2"	66 l/min	660 l/min		no	NL
6820-4	950 10 68204	6823-4	950 10 68234	NW 2,5"	75 l/min	1000 l/min	50 l	yes	D
		6823-4.1 (for V 2000)	950 10 682341	NW 2,5"	75 l/min	1000 l/min	50 l	yes	A, D, CH
6820-8	950 20 68208	6823-1	950 20 68231	NW 2"	25 l/min	660 l/min	20 l	yes	CH
6820-11	950 10 682011	6823-4	950 10 68234	NW 2,5	65 l/min	1330 l/min	50 l	yes	CH
		6823-4.1 (for V 2000)	950 10 682341	NW 2,5"	75 l/min	1000 l/min	50 l	yes	A, D, CH
6820-14	950 20 682014	6823-1	950 20 68231	NW 2"	50 l/min	500 l/min	10 (20) l	no	A
6820-15	950 20 682015	6823-15	950 20 682315	NW 2"	25 l/min	500 l/min	20 l	no	B
		6823-16 ****	950 20 682316	NW 2,5"	75 l/min	1000 l/min	50 l	yes	D
		6823-17 ****	950 20 682317	NW 2"	25 l/min	500 l/min	20 l	yes	D
6820 P017	950 9017 6820			NW 2"	25 l/min	500 l/min	20 l	no	D
6820 P018	950 9018 6820	6823-18	950 20 682318	NW 2"	25 l/min	500 l/min	20 l	no	D
		6823-19.1 (for V 2000)	950 20 6823191	NW 2,5"	75 l/min	1000 l/min	50 l	no	B
		6823-20 **	950 20 682320	NW 3"	100 l/min	2000 l/min	200 l		NZ
6820 P025	950 9025 6820	6823-25	950 20 682325	NW 2,5"	75 l/min	100 l/min	50 l	no	D
6820 P028 *	950 9028 6820	6823-28 *	950 20 682328	NW 2"	25 l/min	500 l/min	20 l	no	PL
6821-14 ***	950 10 682114			NW 2"	50 l/min	500 l/min	10 (20) l		A

* Resolution 0,05 ltr.

*** MID with 3 channel pulse output: coding for 1 channel pulse output, direction signal and error signal

** without 5m-connecting cable

**** MID with 3 channel pulse output: 120° phase displacement

Display unit PD 210	Flush-mounting module in a splashproof plastic case with membrane keyboard.
	Protection type IP64A, 144 x 72 x 8 mm.
	With LCD display for flow velocity, volume (total and limit value) and temperature, plus error code display. (MID without MAK 3001/2 system: PD 210 for entering the calibration factor and for writing the 8 internal registers).
	Order no. 490 10 50701
Accessories	See the enclosed sheet for connectors and threaded couplings.