

## Controller MAK plus, type 6744-10

Efficient computer with LC display and input keyboard in compact design.

It can be applied as central operating, control and display unit in modular systems with high demands on precision and availability even under adverse ambient conditions.

Communication with all system modules via serial fieldbus (P-NET), including Multimaster operation.



The Controller conforms to the CE directives and to the OIML recommendations required for international type approvals in measurement systems for liquids other than water. As a system, it has been granted the type-approval certificate (under German law) of an electrical counter with measured data storage and additional appliances. It can be used in combination with measuring devices requiring calibration.

Keyboard arrangement illuminated, alphanumeric keyboard.

Application of four additional keys with variable functions (softkeys).

LC display illuminated, heated and graphic-capable, for the large temperature range of - 20 ... + 60 °C.

### Application

The device is applied in milk collecting trucks as a data acquisition system to register the quantity and quality of the collected milk, as well as for the automation of the collecting process.

The system capability of the controller permits its almost limitless application to control, monitor and automate processes and transactions.

### Function

On request the controller, being the master in the system, receives data from subordinate modules, e.g. sensors, external memories etc. It edits, processes and stores the data and proceeds according to the implemented program.

In order to control automated transactions, it sends default data or control signals to modules in the P-NET.

Moreover, the Controller has three digital inputs, two outputs and kilometer impulse counter, which are easy to operate and evaluate.

### Advantages

- **Efficient 32-Bit-processor, real-time capable.**
- **1 MB battery-buffered RAM.**
- **Highly adaptable to a variety of applications by means of software.**
- **Operating software can be replaced by means of upload via the fieldbus interface without opening the device.**
- **Creation of user programs in the programming language C++.**
- **Real-time clock.**
- **Service-friendly calibration concept.**

## Technical data

### Mechanical data

Dimensions	B x H x T: 210 x 227 x 130 mm
Material	Aluminium diecast, blue paint, V <sub>2</sub> A sheet metal
Assembly plate	320 x 210 x 10 mm
Weight	65 N (6.5 kg)

### Electrical data

Operating voltage	DC 9 - 33 V from board net (load dump)
External buffer accumulator	DC 24 V ± 5 % battery low. sig. @ 8.6 V disconnection 7 V
Electronics	DC 24 V, 250 mA
Output voltage for peripherals	DC 24 V ± 5 %, 1,0 mA (Si F3A) (P-NET-Ring)
Switching output	2 x DC 24 V, 1,0 A, R <sub>i</sub> 60 m Ω high side f <sub>G</sub> 5 1/s
Digital inputs	3 x high-low side bridgeable, 24 V, 5,11 kΩ, optoinsulated
Analogous input	1 x Pt 100 4 L, 1 mA - 20 °C + 100 °C < 0,1 °C
Milk sensor	24 V @ 5,11 kΩ, optoinsulated from 6703-11/6703-15
Distance	4 V @ 1 mA (tachograph) R <sub>E</sub> 10 Ω optoinsulated 300 1/s max.
Cable feed	8 x PG 9 plastic
Terminals	Plug-and-screw-terminals 14 x 2,5 °, 24 V 16 A, 28 x 1,5 °, 24 V 10 A
Interfaces	P-NET: RS 485, serial, asynchronous, half duplex 76 800 baud, max. 1 200 m twisted pair, galvanically separated RS 232: adjustable up to 9 600 baud

### Ambient conditions

Operating temperature	- 20 ... + 60 °C
Storage temperature	- 30 ... + 85 °C
Protection type	IP 65 nach DIN 40050
Climate class	ISF nach DIN 40040

### Device-specific data

Keyboard	Foil sensor, short-travel 32 + 4 illuminated
Display	Graphic-capable LC display, 160 x 128 Pixel, illuminated, heated, temperature-oriented contrast control, field of vision approx. 96 x 77 mm.
Data processing	32-bit processor, 2 MB Flash-EPROM, 1 MB RAM battery-buffered, 2 kB EEPROM in CPU, 2 x 2 kB EEPROM on power supply PCB, real-time clock, watchdog

## Measurements

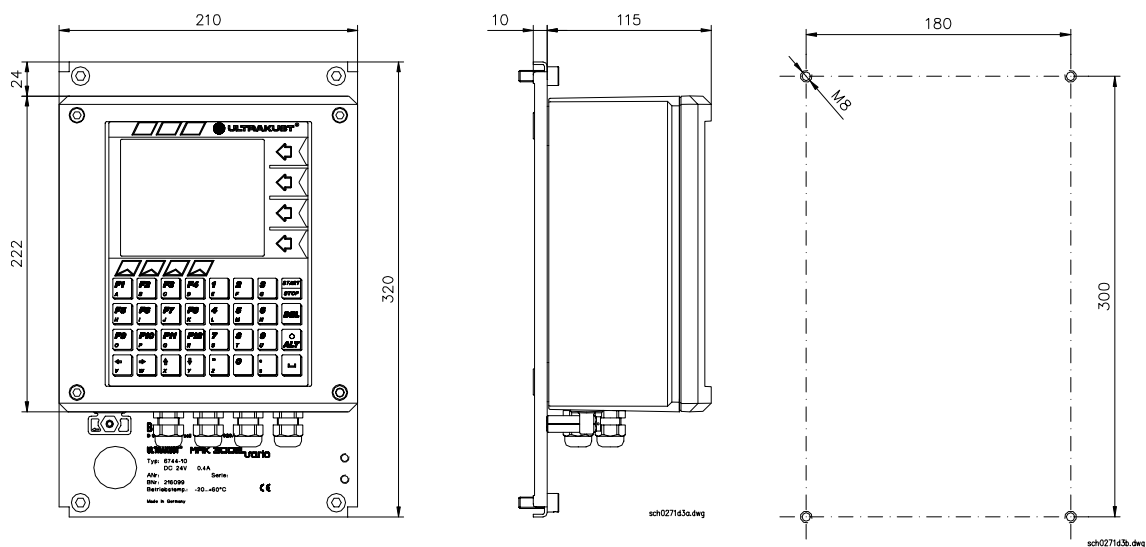

## Order designation

Controller MAK plus type 6744-10

216 099