



Flashing Beacon

Features

- Corrosion resistant marine grade alloy construction
ATEX certified for hazardous areas
- Three independent Xenon tubes with 30 Joules
- Exchangeable coloured Fresnal optic lens
- Design eliminates external junction boxes
- Low cost combined visual/audible warning as standard

Description

The BARTEC VODEC VB3 is an ATEX certified visual warning (alarm) device designed to produce regular pulses of high intensity light.

The unit is specified for use in the most demanding of applications (which include offshore oil installations and refineries) and provides reliable service in extremes of climate.

A robust alloy enclosure resists corrosion risk and will not support organic growths associated with plastic Ex d enclosures.

The enclosure is designed without spigot threaded joint which eliminates seizures and eases maintenance.

VB3 has no moving parts and is based upon Xenon gas discharge tube technology, three tubes are fitted each with dedicated firing electronics to ensure highest integrity.

Beacon colour is fixed by use of a specifically developed fresnal optic lens which provides both efficient light dispersion and simple field changeable colour assignment.

A range of fresnal lens colours are available to assure compliance with worldwide regulations.

It should be noted that the connection to the telephone subscriber line is via high integrity optical isolator which eliminates any possible risk of insulation breakdown between high tension flashing beacon electronics and the telephone system.

VB3 is also fitted with a high power alarm tone drive output to serve an external explosion proof projector horn. A range of alarm tone signals are generated internally and are user selectable by integral tamper proof switches.

External junction boxes are eliminated in all applications of VB3 by provision of up to four M20 gland entries and sufficient discrete terminals to allow cable loop through and connection of all cable screens where fitted.

Explosion protection

Ex protection type
Ex d IIG T3 ATEX certified IP 66

Certification
Baseefa09ATEX0322

Technical Data

Supply input
AC 110/120 V or AC 220/240 V, 50/60 Hz

Power consumption
max. 60 W

Telephone ring voltage
18 up to 60 V RMS

Telephone line loading
REN 1

Combined flash energy
30 Joules

Dimensions
250 mm wide, 350 mm deep

Weight
3 kg

Gland entry
Up to 4 x M20

Operating temperature range
-40 °C to +60 °C

Enclosure colour
Orange RAL 2003
special colours are available

Selection chart alarm tones

Alarm	Tone	Alarm	Tone
1	Ramp 1200 Hz to 500 Hz in 1 sec.	8	500 Hz 1 sec., 1kHz 1 sec., 500 Hz 1 sec. repeating
2	1 kHz, 1 sec. ON - 1 sec. OFF	9	2 kHz, 0.25 sec. ON, 0.25 sec. OFF
3	1 kHz, Continuous Tone	10	1 kHz for 1 sec. / 800 Hz for 1 sec.
4	500 Hz for 0.5 second 1 kHz for 0.5 second	11	500 Hz Continuous Tone
5	7 Short Pulses of 1 kHz for 7 seconds followed by a 1 kHz Blast for 7 sec.	12	800 Hz, 2 sec. ON / 2 sec. OFF
6	800 Hz Continuous Tone	13	1 kHz for 0.25 sec./ 800 Hz, 0.25 sec.
7	800 Hz, 1 sec. ON / 1 sec. OFF	14	1 kHz, 2 sec. ON, 2 sec. OFF
		15	800 Hz, 1 sec. ON, 1 sec. OFF
		16	1 kHz for 1 sec., 500 Hz for 1 sec.

Selection chart fresnal colours

Fresnal colours	Code no.
amber	VBB 001 AM
blue	VBB 001 BL
clear	VBB 001 CL
red	VBB 001 RD
yellow	VBB 001 YL
green	VBB 001 GR



Application diagrams

Beacon application in a PAGA system

Simple diagram shows BARTEC VODEC VB3 emergency visual alarm annunciator as part of an overall PAGA broadcast system. Loop wiring ensures continued operation in event of a single field cable disconnection.

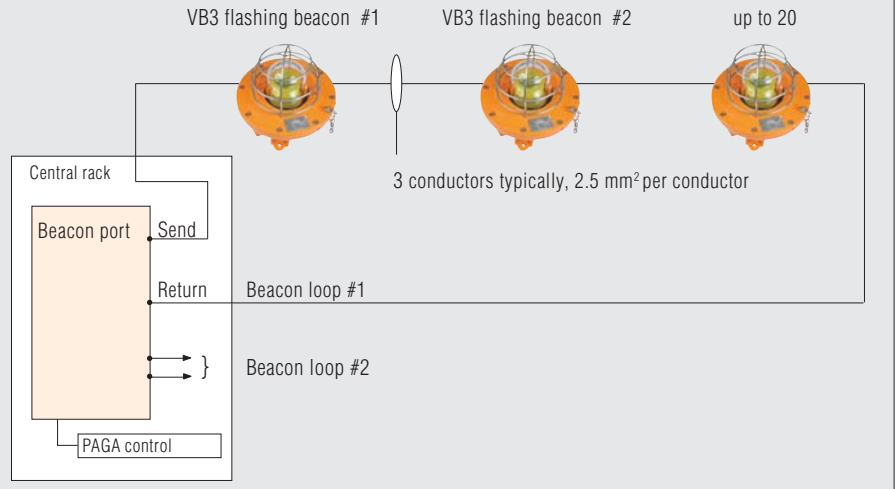

Combined audible/visual warning system (direct switched)

The diagram shows VB3 and explosion proof horn to form a complete alarm annunciator package providing efficient acoustic and visible coverage.

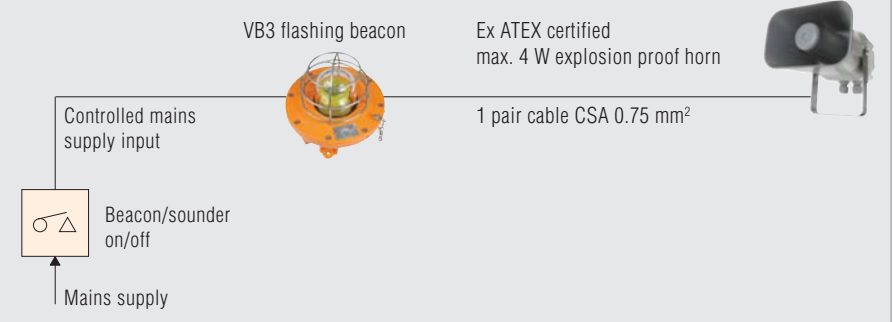

Combined visual warning system (telephone activated)

The VB3 incorporates a telephone ringing voltage detector, upon resolution of ring voltage the beacon is initiated and provides continuous flashing annunciation until the subscriber handset is taken off hook. Telephone line is galvanically isolated from the beacon by integral optical coupling device which assures safety.

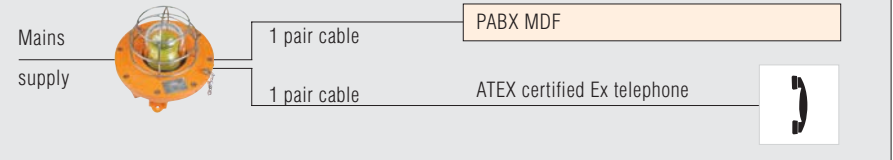

Combined audible/visual warning system (telephone activated)

The VB3 beacon incorporates telephone detector as standard which can be arranged to also drive a supplementary alarm broadcast horn.

